

CONTACT:

ALEXANDRU SCUTURICI

[www.usideinterior.net](http://www.usideinterior.net)

[alexandru@service-usi.eu](mailto:alexandru@service-usi.eu)

0721294477

**lualdi**<sup>®</sup>



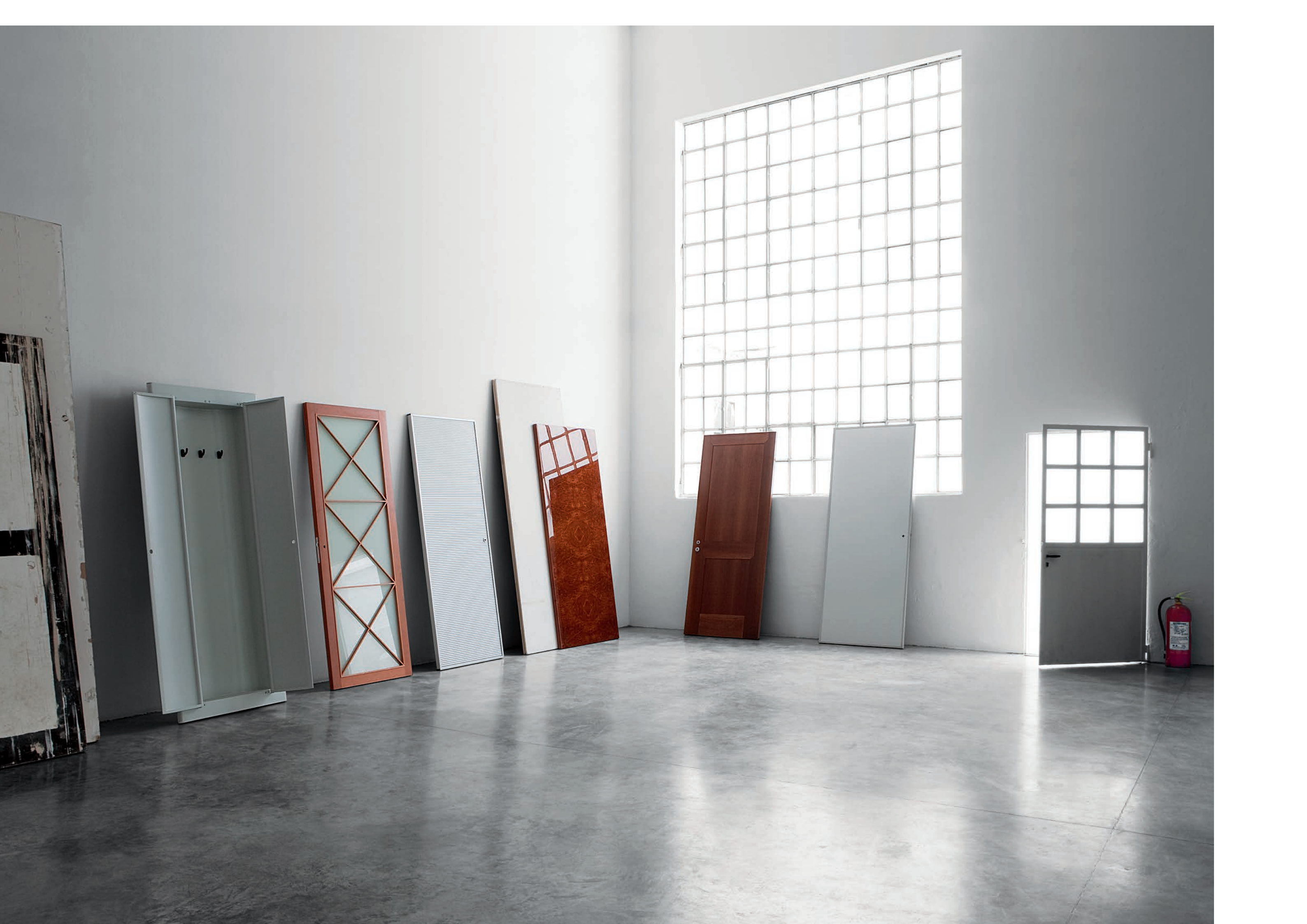



## L16 —

progettata da Piero Lissoni, L16 è pensata per riduzione. Di spessori, innanzi tutto. Straordinariamente sottile, l'anta battente somiglia a un foglio, una pagina nitida, capace di separare gli ambienti con mano leggera e movimento fluido. Ogni elemento visibile è progettato per scomparire. Quel che si offre allo sguardo è una superficie intatta, ripulita di ogni segno, perfettamente uniforme, vero e proprio elemento architettonico in grado di caratterizzare e definire lo spazio, grazie al risalto di essenze e colori.

Designed by Piero Lissoni, L16 is designed to reduce, especially in thickness. Remarkably thin, the hinged door looks like a sheet, an unblemished page, able to separate spaces with a light touch and fluid motion. Each visible element is designed to disappear.

To the eye it offers a flawless surface, free of any imperfection and perfectly uniform; a true architectural element able to characterize and define the space, thanks to the prominence of woods and colors.







Il coprifilo di L16, qui in laccato rosso lucido, può diventare un pannello ed estendersi intorno alla porta con un effetto boiserie di grande impatto decorativo.

The trim of the L16, here in red gloss lacquer, can become a panel and extend out from around the door providing a boiserie effect of great decorative impact.









Come maniglia, un volume puro:  
un cilindro a scelta in corian, acciaio  
satinato o tre finiture di legno.

The handle is a pure volume: a cylinder  
in a choice of Corian, satinized steel  
or three wood finishes.

L16\_011



La purezza di linea di L16 è scaldata dalla finitura materica in thermowood, ed esaltata dalle dimensioni a tutta altezza, da pavimento a soffitto.

The purity of the line of the L16 is warmed by the material finish of thermowood and exalted by its full-height, floor-to-ceiling form.

L16\_012









# L16

pag. 06 – 07  
Laccato rosso lucido  
/ Red gloss lacquer  
pag. 09 – 10 – 11 – 13  
Legno Thermowood  
/ Thermowood  
pag. 015  
Laccato Opaco Arancia  
/ Orange Mat Lacquer



## L16

Porta costruita con materiale composito stabile ed insonorizzato con spessore 16 mm. Serratura magnetica. Cerniere a perno a scomparsa. Guarnizione di battuta. Fasce laterali e fascia superiore possono essere fatte a richiesta su misura. Finitura: laccato opaco, lucido o in essenze di serie.

Composite material door leaf 16 mm thick. Soundproof core. Magnetic lockset. Side and top panels can be custom size. Pivot concealed hinges. Finishes available: matt and glossy lacquer and veneers.

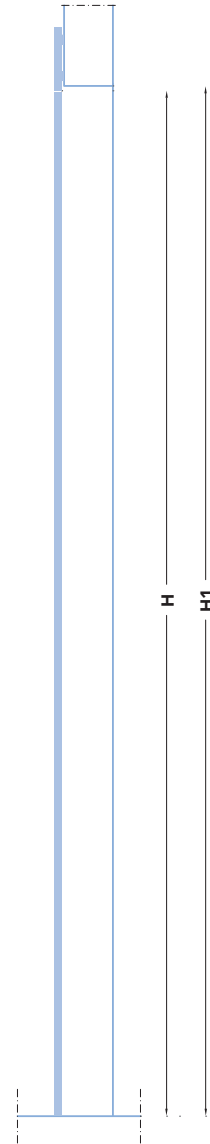

**L**  
Larghezza luce netta  
*Opening width*  
cm 80 31 1/2"  
cm 90 35 3/8"

**L1**  
Luce vano da predisporre  
*Rough Opening*  
cm 82 32 1/4"  
cm 92 36 1/5"

**H**  
Altezza luce netta  
*Opening height*  
cm 210 - 300 82 5/8"-118 1/4"

**H1**  
Luce vano da predisporre  
*Rough Opening*  
cm 211-301 83" - 118 1/2"

apertura a spingere / push opening

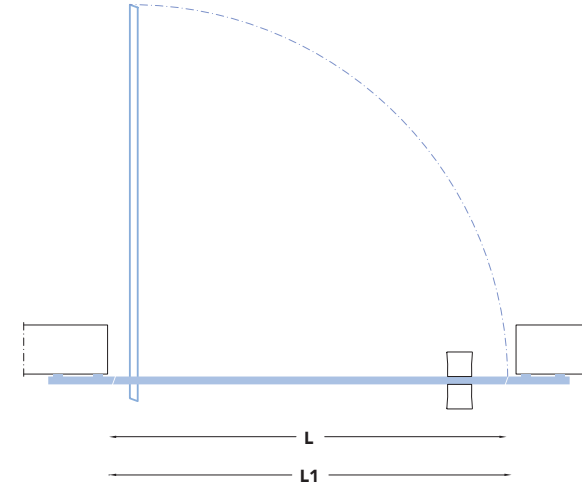

apertura a tirare / pull opening

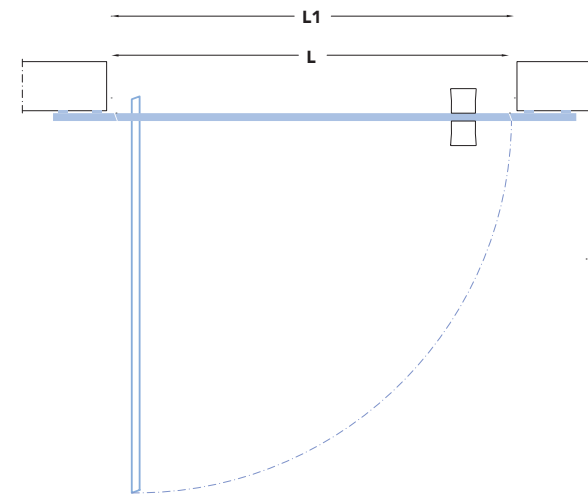



## L41 —

L41 è connotata da un sottile stipite in metallo a valorizzarne il profilo agile.

Progettata da Piero Lissoni ha la particolarità di poter essere realizzata con finiture diverse sui due lati dell'anta, con esiti materici e cromatici interessanti, di originale bellezza.

L41 is distinguished by a thin metal jamb which enhances the light profile. Designed by Piero Lissoni, it is distinguished by the fact that it can be produced with

different finishes for each side of the door, providing interesting combinations of materials and colors and a unique beauty.







Anta in vetro retrolaccato grigio:  
un campo di energia fluida nel colore  
satturo della parete.

Door in grey lacquered glass:  
an expanse of fluid energy within  
the intense color of the wall.



Dettaglio dell'elegante disegno delle cerniere. Il pomolo in legno crea un sapiente contrasto con l'anta in vetro retrolaccato.

Detail of the elegant hinge design. The wooded door knob creates an ingenious contrast to the lacquered glass door.

L41 \_\_022

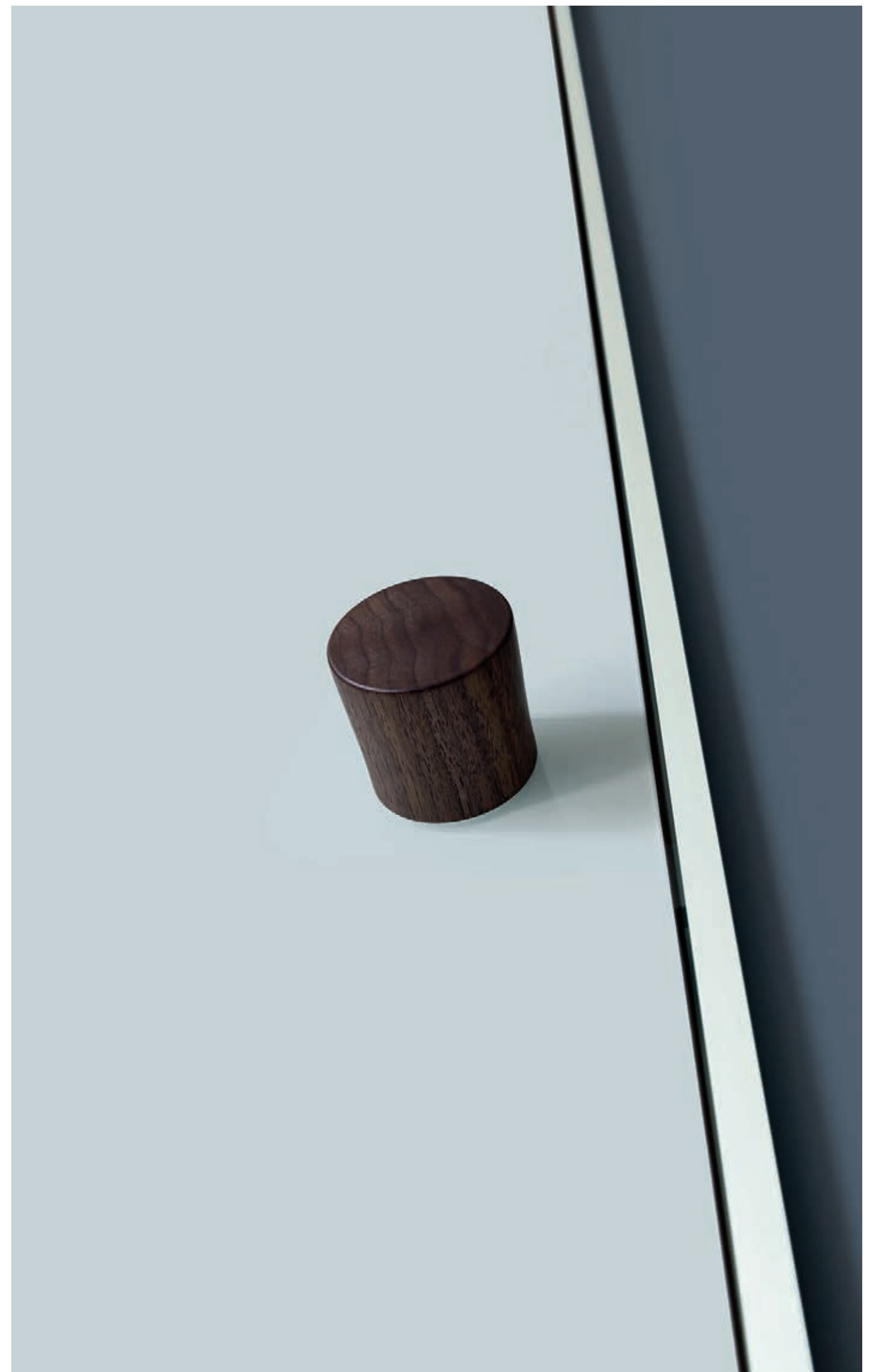









Anta in thermowood con pomolo in acciaio satinato. Stipite e maniglia fanno del metallo un light motif aereo, luminoso.

Door in thermowood with brushed steel knob. The jamb and handle transform the metal into a bright leit-motif.



# L41



versione per muratura / brickwall

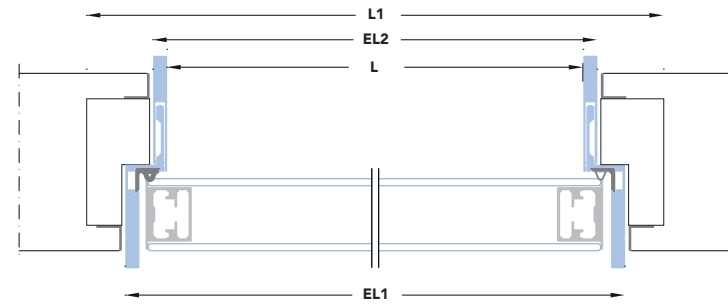

versione per cartongesso / drywall

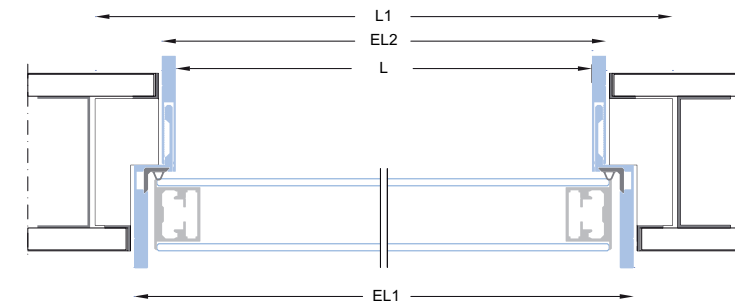

pag. 020 – 021 – 022 - 023  
Vetro laccato grigio  
/ grey lacquered glass  
pag. 024 – 026 – 027  
Legno Thermowood  
/ Thermowood

## L41

Porta con battente a struttura tamburata di spessore mm 41 a lavorazione ultimata, con finitura laccato opaco, lucido ed essenze di serie; oppure con battente con telaio perimetrale in alluminio e lastre di vetro. Stipite in alluminio bianco o nero opaco. Guarnizioni di Battuta. Cerniere a scomparsa. Montaggio su falso telaio dedicato.

Swinging door with a hollow core structure; 1 3/4". thick. Factory pre-finish available in matt and polished lacca as well as Lualdi's standard wood veneers. Glass door version is obtained with aluminum surrounding and choice of full size light glass. The frame is available in white or black matt. Included are silencer and concealed hinges. Installation require a subframe

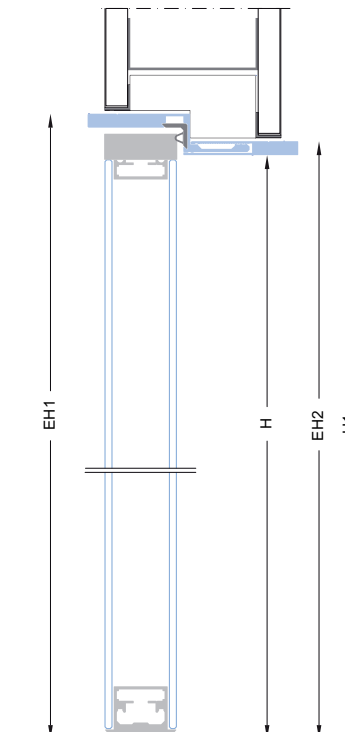
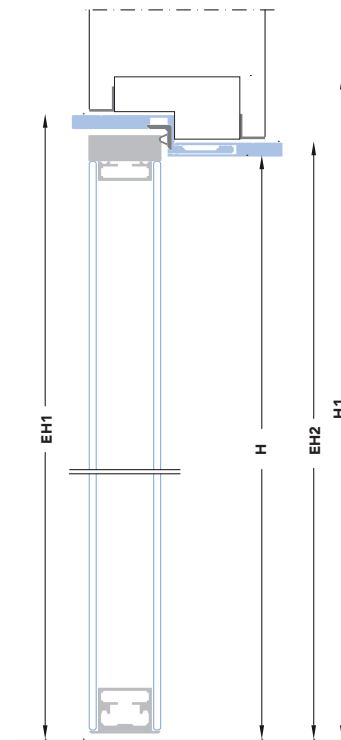

**L**  
Larghezza luce netta  
Opening width  
cm 60 23 5/8"  
cm 70 27 1/2"  
cm 80 31 1/2"  
cm 90 35 3/8"

**H**  
Altezza luce netta  
Opening height  
cm 210 - 300 82 5/8"-118 1/4"

**L**  
Larghezza luce netta  
Opening width  
cm 60 23 5/8"  
cm 70 27 1/2"  
cm 80 31 1/2"  
cm 90 35 3/8"

**H**  
Altezza luce netta  
Opening height  
cm 210 - 300 82 5/8"-118 1/4"

**L1 - H1**  
Ingombro falso telaio  
Subframe dimensions  
cm 69,2 x 214,6 - 304,6  
27 1/4" x 84 1/2" - 119 9/10"  
cm 79,2 31 1/6"  
cm 89,2 35 1/8"  
cm 99,2 39"

**EL1 - EH1**  
Ingombro max esterno stipite  
Frame max external dimensions  
cm 64,8 x 212,4 - 302,4  
25 1/2" x 83 2/3" - 119"  
cm 74,8 29 1/2"  
cm 84,8 33 2/5"  
cm 94,8 37 1/3"

**EL2 - EH2**  
Ingombro esterno stipite  
Frame external dimensions  
cm 61,6 x 210,8 - 300,8  
24 1/4" x 83" - 118 2/5"  
cm 71,6 28 1/5"  
cm 81,6 31 1/7"  
cm 91,6 36"

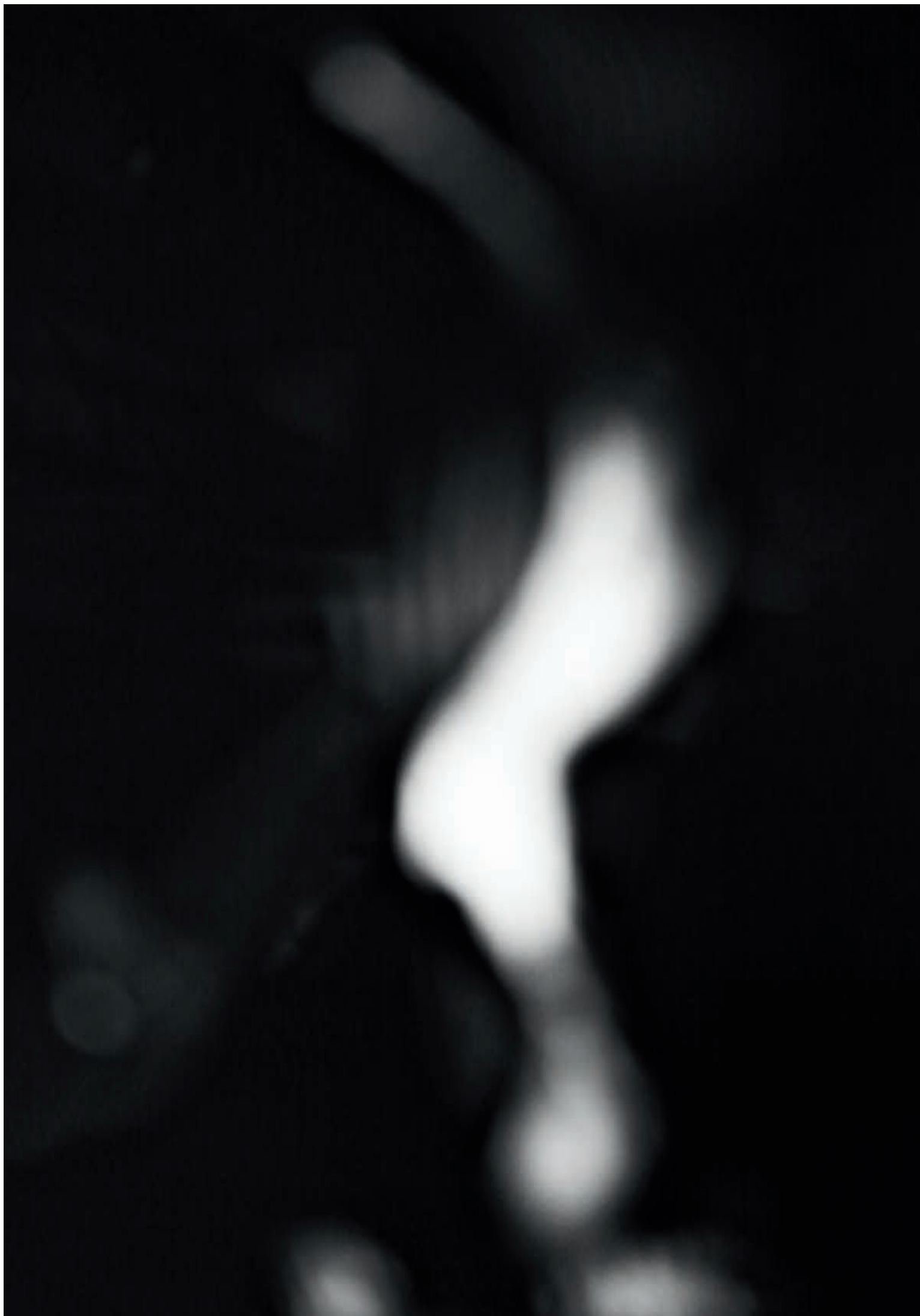

## Rasomuro 55s —

è la naturale evoluzione del modello storico Rasomuro, di cui riprende ed esaspera le caratteristiche tecniche che ne hanno decretato il successo. Grazie alle cerniere completamente a scomparsa, al forte spessore e allo stipite invisibile in alluminio, è in grado di integrarsi alla parete con mimetismo perfetto.

This is the natural evolution of the celebrated model Rasomuro, borrowing and embellishing the technical features that were so key to its success. Thanks to the concealed hinging,

the substantial thickness and the invisible aluminium doorjamb, this model is able to assimilate perfectly with the wall.



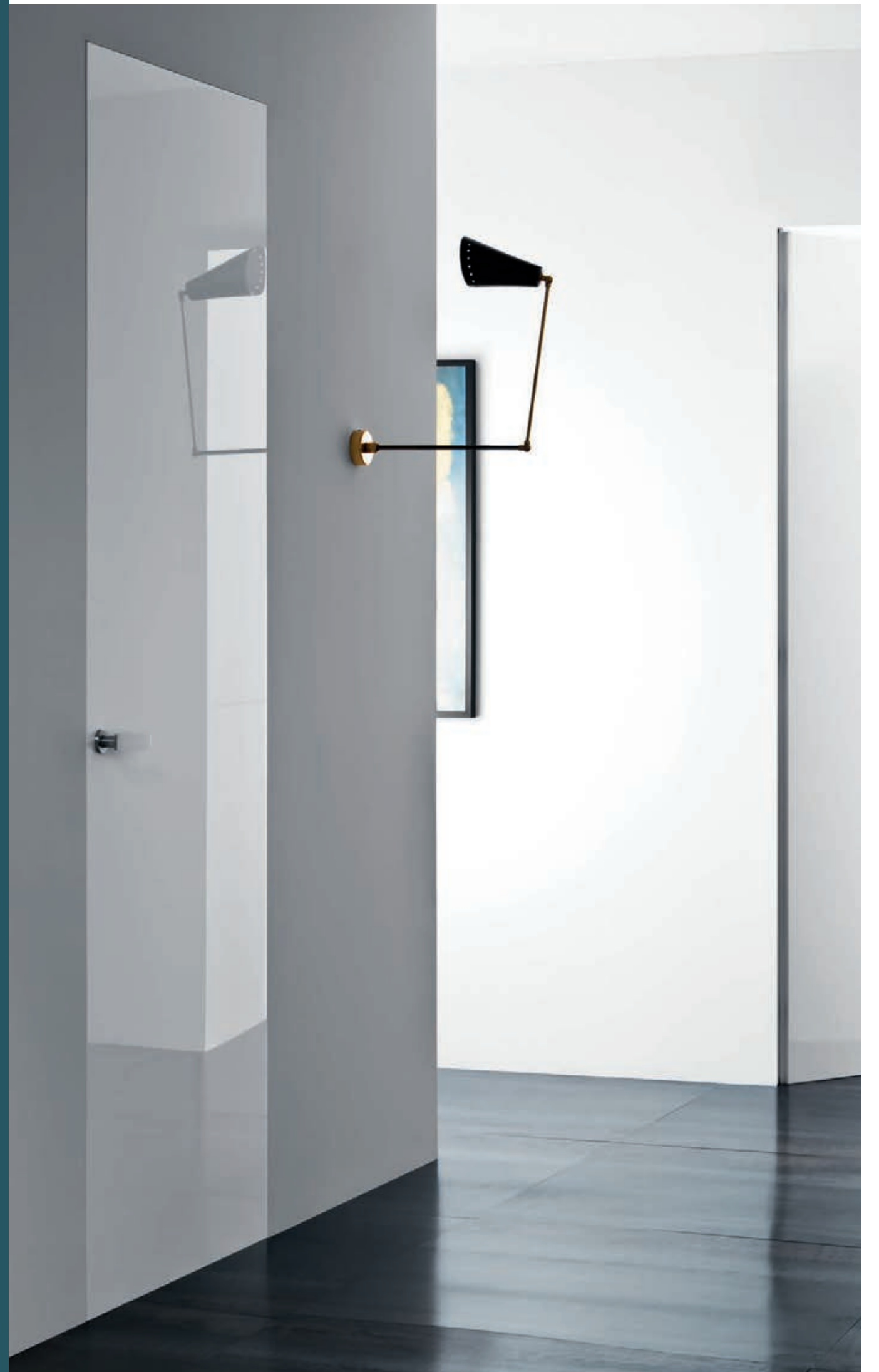







Rasomuro 55s \_036





Perfettamente complanare e sviluppata a tutta altezza, Rasomuro 55 ha la precisione di un intarsio. La finitura è laccato opaco verde smeraldo. A lato, dettagli di cerniera e stipite.

Full height and perfectly flush, Rasomuro 55 exhibits the precision of a piece of marquetry. The finish is emerald green matte lacquer. Left, details of the hinge and doorjamb.





## Rasovetro 55s —

Rasovetro nasce da Rasomuro e della famiglia ha tutte le caratteristiche, come le cerniere a scomparsa e lo stipite in alluminio. Esteticamente, invece, sviluppa la propria originalità grazie al vetro, materiale pulito per eccellenza, e alle sue prerogative uniche: trasparenza, luminosità, leggerezza.

Rasovetro derives from Rasomuro and shares all its characteristics, such as the concealed hinges and the aluminium jamb. However, it demonstrates its own aesthetic

originality thanks to the glass, the purest of materials, and its unique features of transparency, luminosity and lightness.

Anta in vetro retrolaccato:  
una presenza capace di accendere  
lo spazio di sofisticati riflessi.

Lacquered door: capable  
of lighting up a space with  
sophisticated reflections.

**Rasovetro 55s**\_042







Dettaglio della maniglia, agile ed essenziale, in accordo con le caratteristiche di Rasovetro. Nella foto a destra: la finitura in vetro opalino crea un morbido effetto di luminosità.

Detail of the light and elemental handle that complements the characteristics of Rasovetro. In the photograph on the right: the finish in opal glass creates a soft brightness.

**Rasovetro 55s**\_044





La trasparenza del vetro opalino conferisce allo spazio un'eleganza lieve, naturale.

The transparency of the opal glass lends a light and natural elegance to the space.

**Rasovetro 55s\_047**



Il sottile telaio in alluminio si legge  
come un profilo luminoso a delimitare  
la superficie in vetro laccato lucido  
grigio scuro.

The thin aluminium frame appears like  
a luminous profile to define the dark  
grey gloss lacquer glass surface.

**Rasovetro 55s** \_048



## Rasotouch —

Rasotouch è il modello più invisibile della famiglia, creato per scomparire completamente nello spazio circostante.

Tocco di perfetta eleganza, la maniglia a scomparsa: un taglio verticale che corre lungo l'anta con la rapidità del più semplice fra i segni: una linea. Design Cairoli & Donzelli.

Rasotouch is the most invisible model of the family, specifically created to disappear completely into the surrounding space.

The recessed handle is a touch of perfect elegance: a vertical cut runs along the door in the simplest of forms - a straight line.









Finitura in laccato opaco bianco: la porta diventa un elemento architettonico vero e proprio che concorre a rendere lo spazio armonico e omogeneo.

Finished in mat white lacquer: the door becomes a true architectural element which contributes to making the space both uniform and harmonious.





Pratica ed efficiente, la maniglia a scomparsa garantisce una presa facile e gradevole.

Practical and efficient, the recessed handle provides an easy and comfortable grip.

Rasotouch\_056



# Raso muro 55s



pag. 033 – 034 – 035  
 laccato bianco lucido  
 / white gloss lacquer,  
 pag. 037  
 grezzo rivestito con tappezzeria  
 / unfinished version wallpapered,  
 pag. 036  
 grezzo dipinto come la parete  
 / unfinished version painted as wall,  
 pag. 038  
 laccato verde smeraldo opaco  
 / emerald green matte lacquer

## Rasomuro 55s

Anta a battente in tamburato, spessore mm 55. Finiture del battente: grezzo con una mano di fondo; laccato opaco e laccato lucido nei colori di serie, essenza di rovere (sbiancato, moka, grigio). Telaio in alluminio; non necessita di falso telaio. Guarnizione di battuta. Cerniera a scomparsa regolabile.

Hollow core hinged door, 55 mm thick. Door panel finish: unfinished with a primer coat, gloss and matte lacquer from standard color range, oak veneer (bleached, moka, grey). Aluminium frame for direct wall installation. Subframe not necessary. Adjustable concealed hinges. Door striker seal.

RM55s spingere per muratura / brickwall push opening

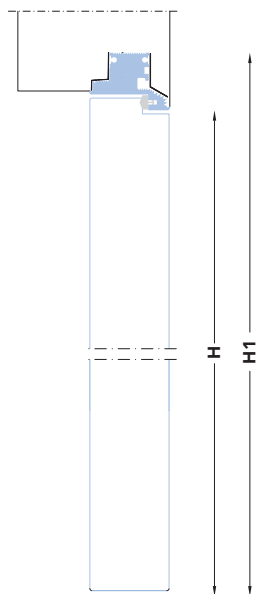
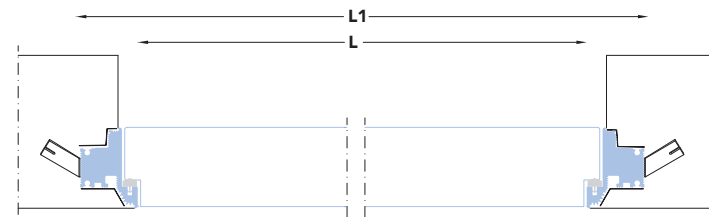

**L**  
 Larghezza luce netta  
 Opening width  
 cm 60 23 5/8"  
 cm 70 27 1/2"  
 cm 80 31 1/2"  
 cm 90 35 3/8"

**L1**  
 Luce vano da predisporre  
 Rough Opening  
 cm 69 27"  
 cm 79 30 7/8"  
 cm 89 34 7/8"  
 cm 99 38 3/4"

**H**  
 Altezza luce netta  
 Opening height  
 cm 210 - 300 82 5/8"-118 1/4"

**H1**  
 Luce vano da predisporre  
 Rough opening  
 cm 214,5 - 304,5 84 5/8"-120"

RM55s tirare per muratura / brickwall pull opening

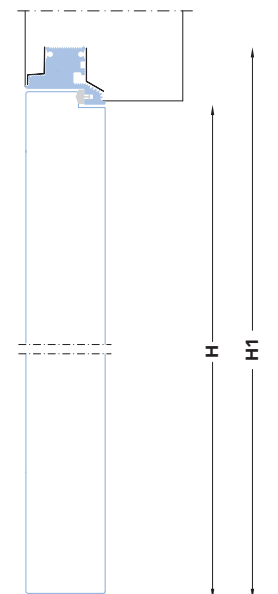
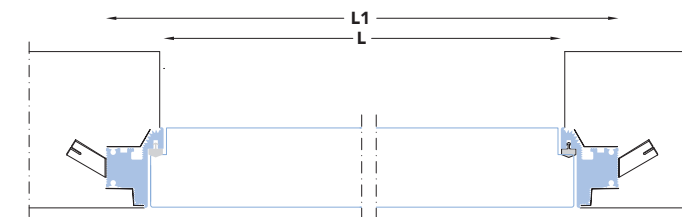

**L**  
 Larghezza luce netta  
 Opening width  
 cm 60 23 5/8"  
 cm 70 27 1/2"  
 cm 80 31 1/2"  
 cm 90 35 3/8"

**L1**  
 Luce vano da predisporre  
 Rough Opening  
 cm 69 27"  
 cm 79 30 7/8"  
 cm 89 34 7/8"  
 cm 99 38 3/4"

**H**  
 Altezza luce netta  
 Opening height  
 cm 210-300 82 5/8"-118 1/4"

**H1**  
 Luce vano da predisporre  
 Rough Opening  
 cm 214,5-304,5 84 5/8"-120"



**RM55s spingere per cartongesso / drywall push opening**

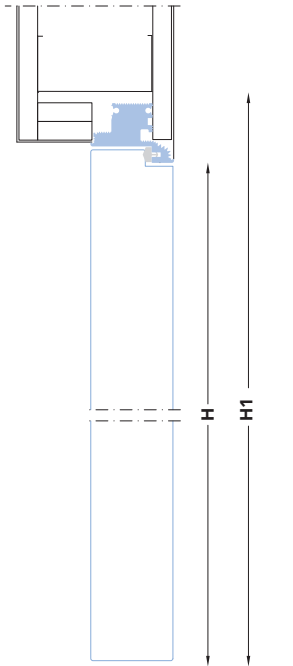
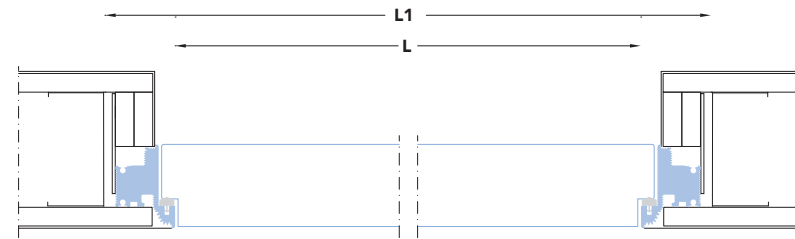

**L**  
Larghezza luce netta  
Opening width  
cm 60 23 5/8"  
cm 70 27 1/2"  
cm 80 31 1/2"  
cm 90 35 3/8"

**L1**  
Luce vano da predisporre  
Rough opening  
cm 69,5 27 3/8"  
cm 79,5 31 3/8"  
cm 89,5 35 1/2"  
cm 99,5 39 1/4"

**H**  
Altezza luce netta  
Opening height  
cm 210-300 82 5/8"- 118 1/4"

**H1**  
Luce vano da predisporre  
Rough opening  
cm 214,5-304,5 84 5/8"-120"

**RM55s tirare per cartongesso / drywall pull opening**

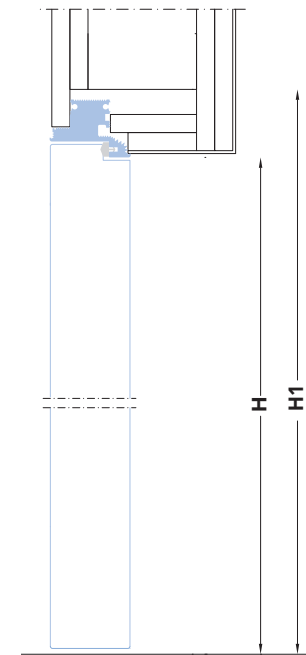
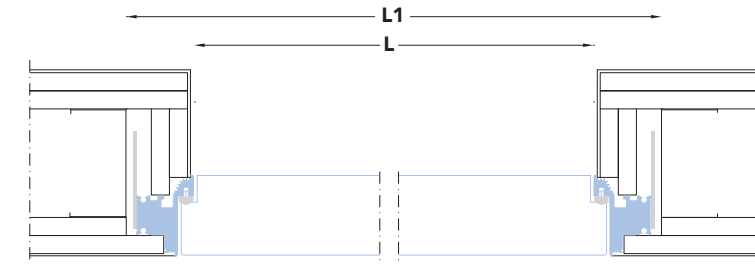

**L**  
Larghezza luce netta  
Opening width  
cm 60 23 5/8"  
cm 70 27 1/2"  
cm 80 31 1/2"  
cm 90 35 3/8"

**L1**  
Luce vano da predisporre  
Rough opening  
cm 69,5 27 3/8"  
cm 79,5 31 3/8"  
cm 89,5 35 1/2"  
cm 99,5 39 1/4"

**H**  
Altezza luce netta  
Opening height  
cm 210-300 82 5/8"- 118 1/4"

**H1**  
Luce vano da predisporre  
Rough opening  
cm 214,5-304,5 84 5/8"-120"

# Raso vetro 55s



pag. 043  
vetro laccato grigio chiaro  
/ light grey lacquered glass  
pag. 044 – 045 – 046  
vetro opalino / opal glass  
pag. 049  
vetro laccato grigio scuro  
/ dark grey lacquered glass

## Rasovetro 55s

Battente spessore mm 55 con telaio perimetrale in alluminio e lastre di vetro temperato spessore mm 4 da entrambi i lati. Vetri finiture di serie. Telaio in alluminio.

Swinging leaf door 55 mm thick composed by aluminum surrounding and 4 mm tempered glass sheets thick on both sides. Available Glass finishes as per Lualdi's chart. Aluminum frame.

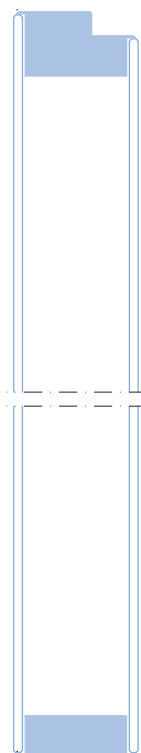

**L**  
Larghezza luce netta  
Opening width  
cm 60 23 5/8"  
cm 70 27 1/2"  
cm 80 31 1/2"  
cm 90 35 3/8"

**H**  
Altezza luce netta  
Opening height  
cm 210-300 82 5/8" - 118 1/4"

# Raso touch



pag. 053 – 054 – 056 – 057  
laccato opaco bianco  
/ white matte lacquer

## Rasotouch design Cairoli & Donzelli

Battente spessore mm 55 con maniglia a scomparsa, l'apertura è ottenuta con pressione della fascia verticale. Battente laccato opaco, lucido o in essenza di serie. Fascia a pressione sempre laccata colore opaco. Telaio in alluminio.

Swinging wood door 55 mm thick with a concealed incorporated handle. The handle operates by pressing the vertical band. Factory pre-finish available in matt and polished lacca as well as Lualdi's standard wood veneers. (Handle's vertical band always lacquered in opaque color) Aluminum frame.

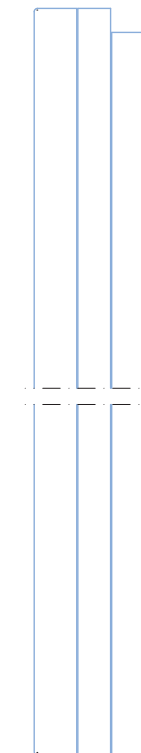

**L**  
Larghezza luce netta  
Opening width  
cm 60 23 5/8"  
cm 70 27 1/2"  
cm 80 31 1/2"  
cm 90 35 3/8"

**H**  
Altezza luce netta  
Opening height  
cm 210-300 82 5/8" - 118 1/4"





## Rasomuro 41 \_

il sottile stipite e le cerniere esterne in alluminio sono i tratti distintivi di questo modello storico, fondato sull'idea innovativa di un allineamento perfetto fra porta e parete, per un effetto di grande pulizia formale.

The slim doorjamb and external hinge in aluminium are the distinctive features of this classic model, based around

the innovative idea of a flawless alignment of door and wall to create a clean, formal look.









Le cerniere a vista, in alto e in basso, si ispirano a un'idea high tech di design, che fa della tecnologia un segno positivo, da rendere visibile.

The visible hinges at top and bottom were inspired by a high-tech idea of design, whereby technology is seen as a positive element to be displayed.

# Raso muro 41



pag. 066  
laccato grigio lucido  
/ grey gloss lacquer  
pag. 068 - 069  
laccato bianco opaco  
/ white matte lacquer

## Rasomuro 41

Porta a battente in tamburato, spessore mm.41. Finiture del battente: grezzo con una mano di fondo; laccato opaco nei colori di serie, essenza di rovere (sbiancato, moka, grigio). Telaio stipite in alluminio anodizzato, non necessita di falso telaio. Guarnizione di battuta. Cerniera esterna a pollice.

Hollow core hinged door, 41 mm thick. Door panel finish: unfinished with a primer coat, gloss and matte lacquer from standard color range, oak veneer (bleached, moka, grey). Anodized aluminium frame for direct wall installation. Subframe not necessary. Concealed pivot hinges. Door striker seal.

**L**  
Larghezza luce netta  
Opening width  
cm 60 23 5/8"  
cm 70 27 1/2"  
cm 80 31 1/2"  
cm 90 35 3/8"

**EL**  
Ingombro esterno  
Max external dimensions  
cm 64 25 1/4"  
cm 74 29 1/2"  
cm 84 33 1/8"  
cm 94 37"

rasomuro spingere per muratura / brickwall push opening

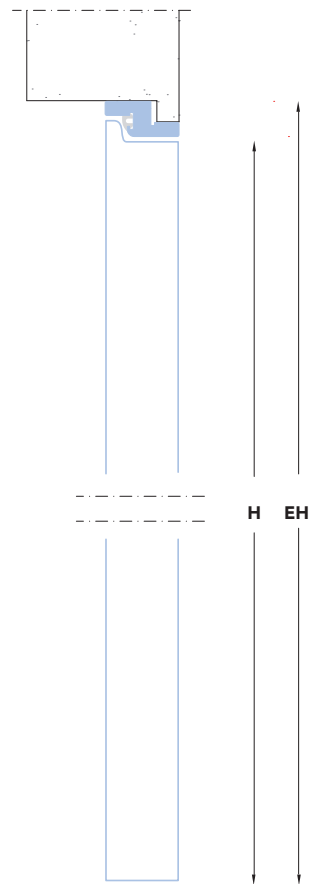
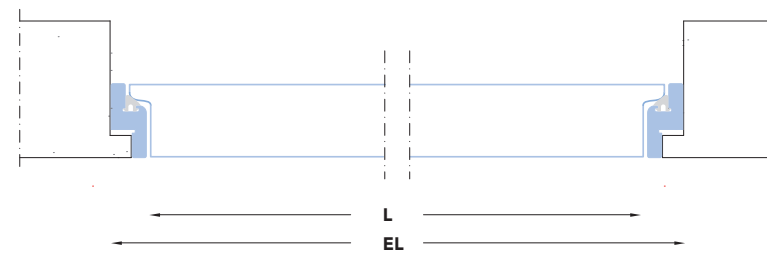

**H**  
Altezza luce netta  
Opening height  
cm 210 - 300 82 5/8"-118 1/4"

**EH**  
Ingombro esterno  
Max external dimensions  
cm 212 - 302 83 1/2"-118"

rasomuro tirare per muratura / brickwall pull opening

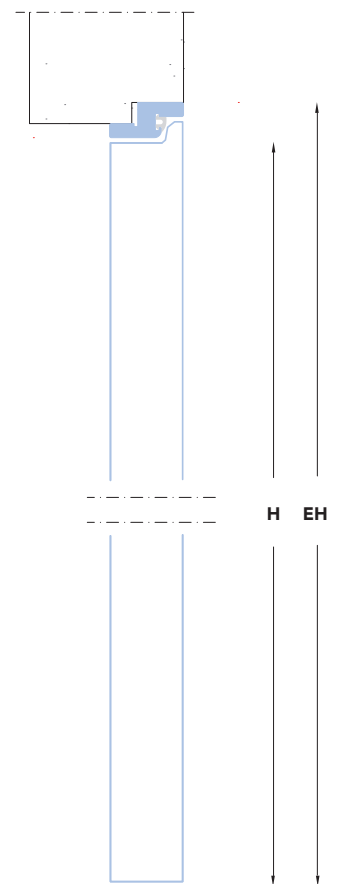

**L**  
Larghezza luce netta  
Opening width  
cm 60 23 5/8"  
cm 70 27 1/2"  
cm 80 31 1/2"  
cm 90 35 3/8"

**EL**  
Ingombro esterno  
Max external dimensions  
cm 64 25 1/4"  
cm 74 29 1/2"  
cm 84 33 1/8"  
cm 94 37"

**H**  
Altezza luce netta  
Opening height  
cm 210-300 82 5/8"-118 1/4"

**EH**  
Luce vano da predisporre  
Rough opening  
cm 212 - 302 83 1/2"-118"



# Raso muro 41



rasomuro per muratura XFT / with subframe

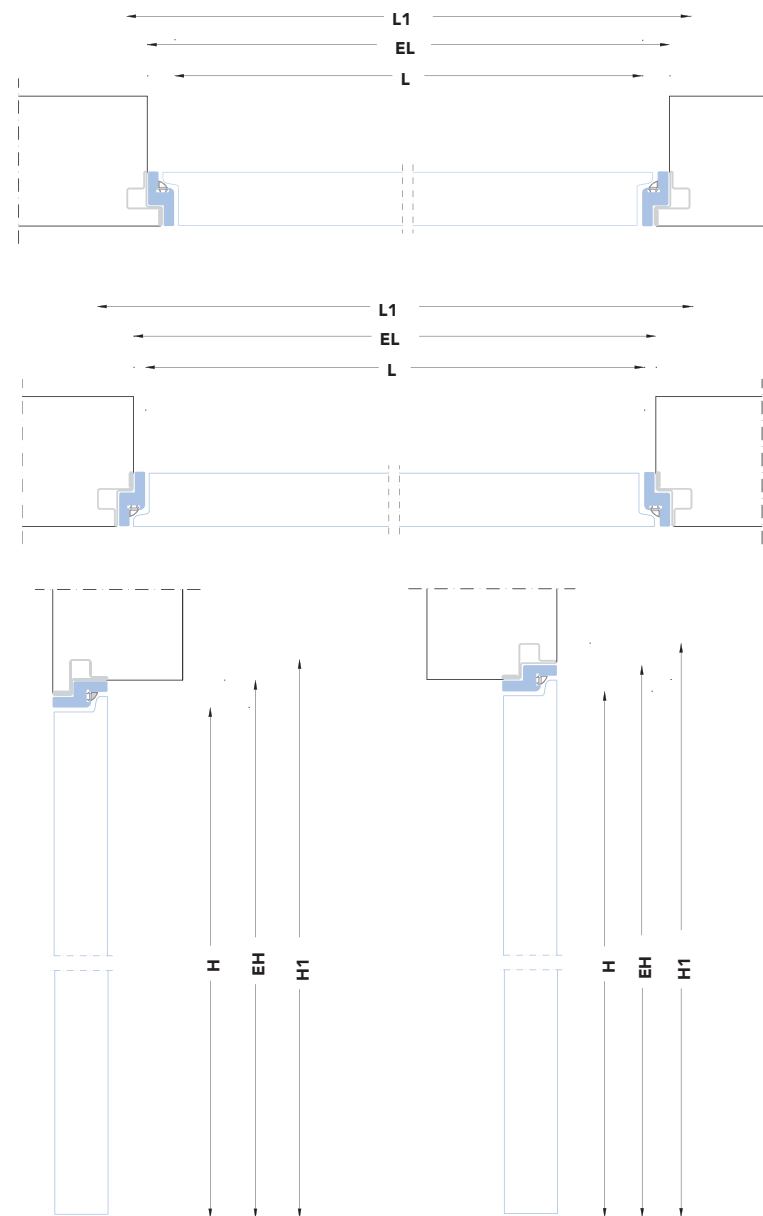

## Rasomuro 41

Porta a battente in tamburato, spessore mm.41. Finiture del battente: grezzo con una mano di fondo; laccato opaco nei colori di serie, essenza di rovere (sbiancato, moka, grigio). Telaio in alluminio anodizzato, da montare su falso telaio in lamiera zincata. Guarnizione di battuta. Cerniera esterna a pollice.

Hollow core hinged door, 41 mm thick. Door panel finish: unfinished with a primer coat, gloss and matte lacquer from standard color range, oak veneer (bleached, moka, grey). Anodized aluminium frame, metal subframe needed for brick wall. Concealed pivot hinges. Door striker seal.

**L**  
Larghezza luce netta  
Opening width  
cm 60 23 5/8"  
cm 70 27 1/2"  
cm 80 31 1/2"  
cm 90 35 3/8"

**L1**  
Ingombro esterno  
max external dimensions  
cm 67,4 26 1/2"  
cm 77,4 30 1/2"  
cm 87,4 34 3/8"  
cm 97,4 38 3/8"

**H**  
Altezza luce netta  
Opening height  
cm 210 - 300 82 5/8"-118 1/4"

**H1**  
Ingombro esterno  
max external dimensions  
cm 213,8 - 303,8 84 1/8-119 2/3"

**EL**  
Ingombro stipite  
Frame dimensions  
cm 64 25 1/4"  
cm 74 29 1/2"  
cm 84 33 1/8"  
cm 94 37"

**EH**  
Ingombro stipite  
Frame dimensions  
cm 212 - 302 83 1/2-118"

rasomuro per cartongesso / drywall

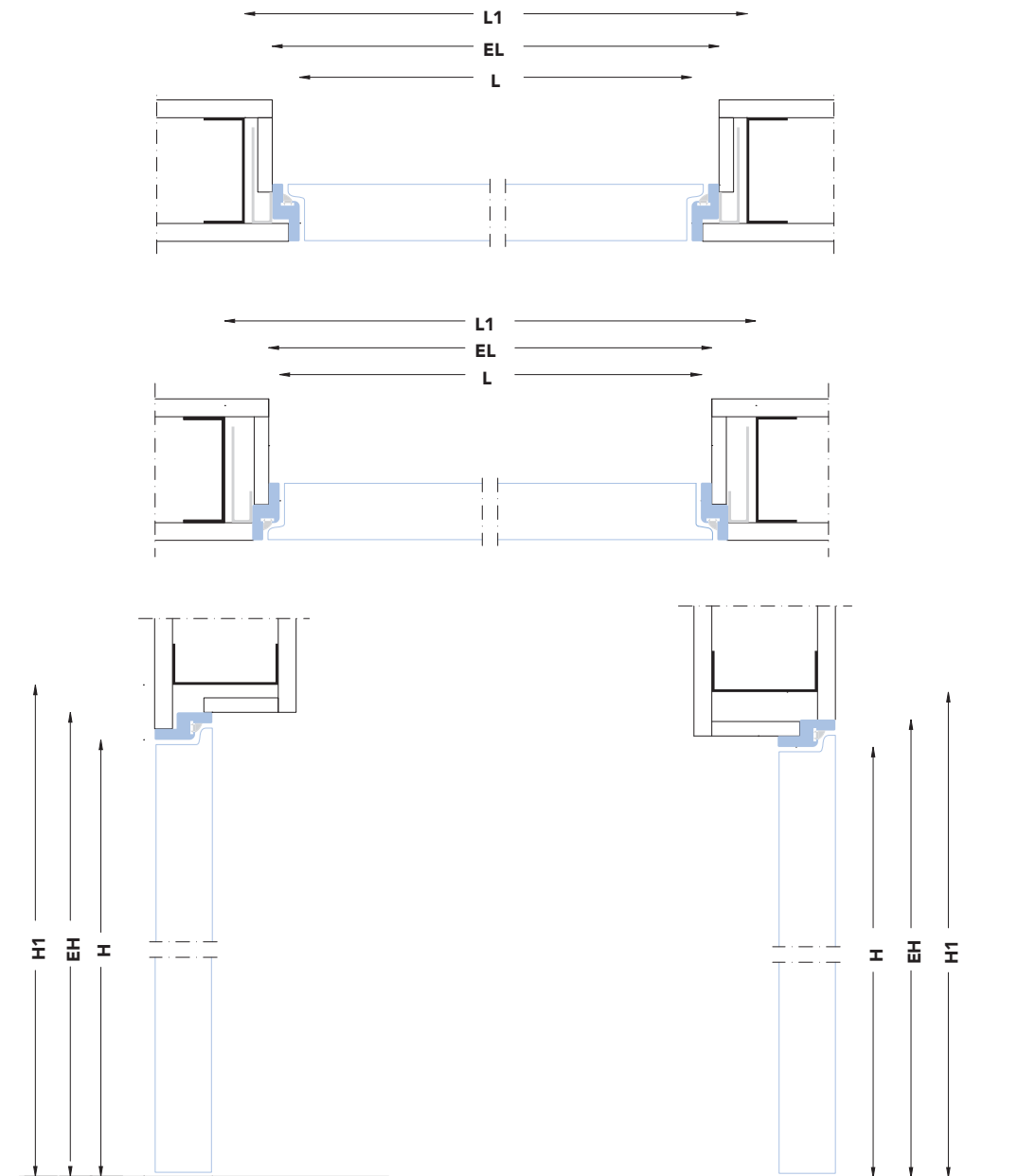

**L**  
Larghezza luce netta  
Opening width  
cm 60 23 5/8"  
cm 70 27 1/2"  
cm 80 31 1/2"  
cm 90 35 3/8"

**L1**  
Luce vano da predisporre  
Rough opening  
cm 69 27"  
cm 79 30 7/8"  
cm 89 34 7/8"  
cm 99 38 3/4"

**H**  
Altezza luce netta  
Opening height  
cm 210-300 82 5/8"-118 1/4"

**H1**  
Luce vano da predisporre  
Rough opening  
cm 214,5-304,5 84 5/8-120"

**EL**  
Ingombro stipite  
Frame dimensions  
cm 64 25 1/4"  
cm 74 29 1/2"  
cm 84 33 1/8"  
cm 94 37"

**EH**  
Ingombro stipite  
Frame dimensions  
cm 212 - 302 83 1/2-118"



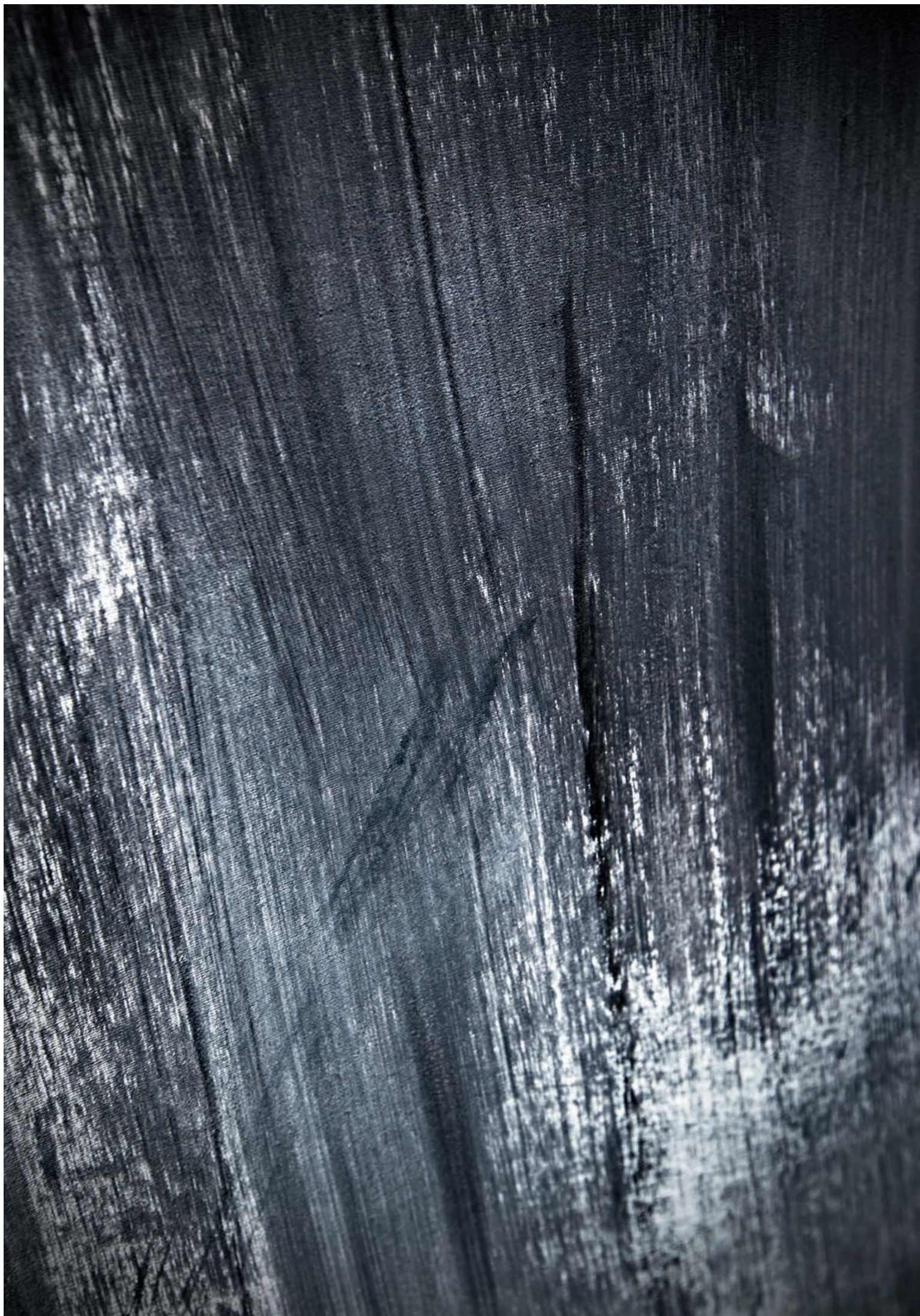

**Compass + Wall & Door** —  
perfettamente allineata, dotata  
di anta pivottante e autochiusura  
controllata, Compass ha l'aspetto  
di una quinta ampia e silenziosa,  
capace di mettere in comunicazione  
gli spazi con leggerezza.  
Wall & Door è un sistema  
che assembla pannelli modulari,  
ante e porte, pensato come  
soluzione per razionalizzare,  
definire e rendere più omogenee  
le superfici di uno stesso ambiente.

Perfectly aligned and equipped with a self-closing hinged door, Compass can be compared to a large, silent stage curtain, enabling areas to communicate with lightness.

Wall & Door is a system composed of modular panels and doors, created to rationalize, define and harmonize the surfaces of a setting.



Una qualità estetica particolare, ottenuta grazie al gioco delle rette perpendicolari fra muro, porta, pavimento. La finitura è laccato lucido bianco 5L.

A particular aesthetic quality arising from the effect of the perpendicular lines between the wall, door and floor. The finish is 5L gloss white lacquer.





Dettagli della serratura magnetica  
e della maniglia Outline in nichel  
satinato.

Detail of the magnetic lock and  
the Outline handle in brushed nickel.

**Compass\_078**





Nello spazio opaco del muro, la superficie di Compass, in laccato nero lucido, si legge come geometria brillante e sofisticata.

The black gloss lacquered surface of Compass appears as a bright and sophisticated geometry in the matte space of the wall.

**Compass\_080**



# Compass — 55

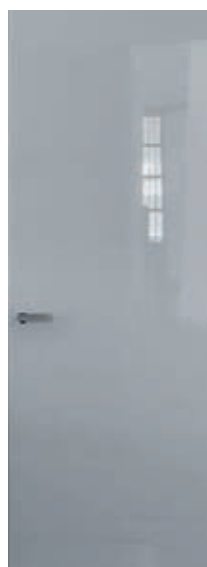

versione per muratura / brickwall

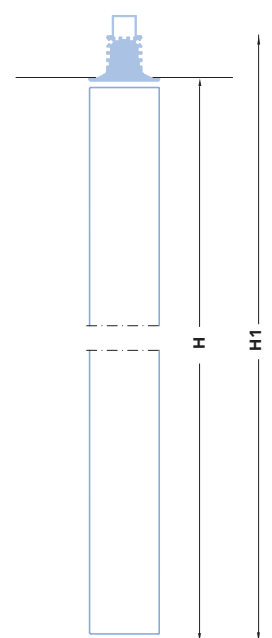
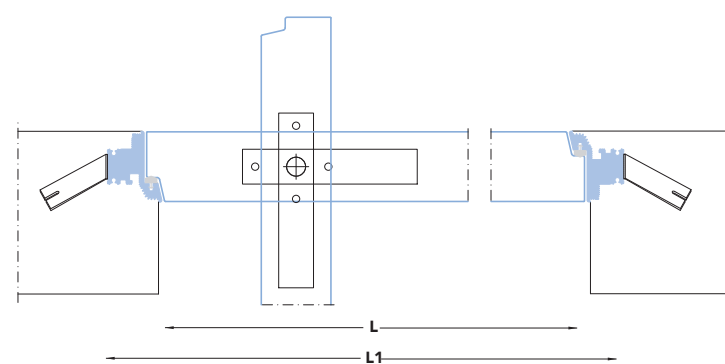

## Compass 55

Porta a battente con anta a struttura tamburata di spessore 55 mm. Finitura del battente: grezzo con mano di fondo, laccato lucido o opaco nei colori di serie, impiallacciato verticalmente in essenze di serie. Impiallacciatura orizzontale solo su richiesta. Telaio-stipite in alluminio anodizzato preassemblato da murare. Non necessita di falso telaio. Guarnizioni di battuta. Cerniere a scomparsa.

Hollow core hinged door, 55 mm thick. Door panel: unfinished with a primer coat, gloss and matte lacquer from standard color range, vertically aligned veneers from standard range. Horizontal veneer on request. Jamb and door frame in pre-assembled anodized aluminium for direct wall installation. Subframe not necessary. Door striker seal. Concealed hinges.

### L

Larghezza luce netta  
Opening width  
cm 60 23 5/8"  
cm 70 27 1/2"  
cm 80 31 1/2"  
cm 90 35 3/8"

### H

Altezza luce netta  
Opening height  
cm 210-300 82 5/8" - 118 1/4"

### L1 - H1

Luce vano da predisporre  
Rough opening  
cm 69x214,5-304,5 28" x 84 5/8"-120"  
cm 79x214,5-304,5 31 7/8" x 84 5/8"-120"  
cm 89x214,5-304,5 35 7/8" x 84 5/8"-120"  
cm 99x214,5-304,5 39 3/4" x 84 5/8"-120"

versione per cartongesso / drywall

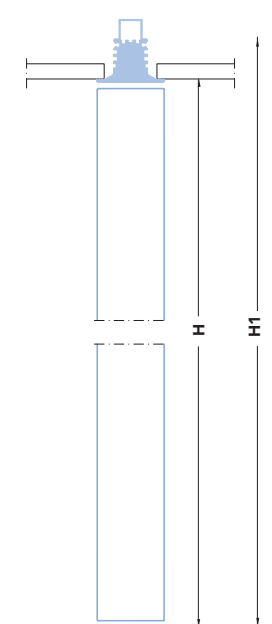
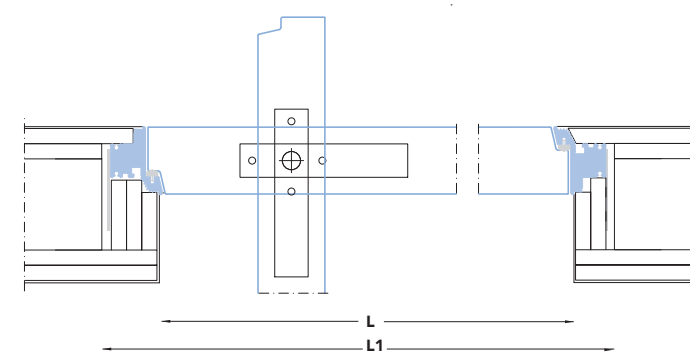

### L

Larghezza luce netta  
Opening width  
cm 60 23 5/8"  
cm 70 27 1/2"  
cm 80 31 1/2"  
cm 90 35 3/8"

### H

Altezza luce netta  
Opening height  
cm 210-300 82 5/8" - 118 1/4"

### L1 - H1

Luce vano da predisporre  
Rough opening  
cm 69x214,5-304,5 28" x 84 5/8"-120"  
cm 79x214,5-304,5 31 7/8" x 84 5/8"-120"  
cm 89x214,5-304,5 35 7/8" x 84 5/8"-120"  
cm 99x214,5-304,5 39 3/4" x 84 5/8"-120"





Wall & Door in rovere thermowood  
verticale: tutta l'eleganza di una  
tradizionale boiserie, calda e materica,  
reinterpretata da un design ultra  
essenziale.

Wall & Door in vertical oak thermowood:  
all the elegance of warm and material  
traditional boiserie, a reinterpretation  
of an extremely essential design.

# Wall & Door

pag. 084 – 085  
rovere scuro  
/ oak veneer



wall & door a battente / swing door

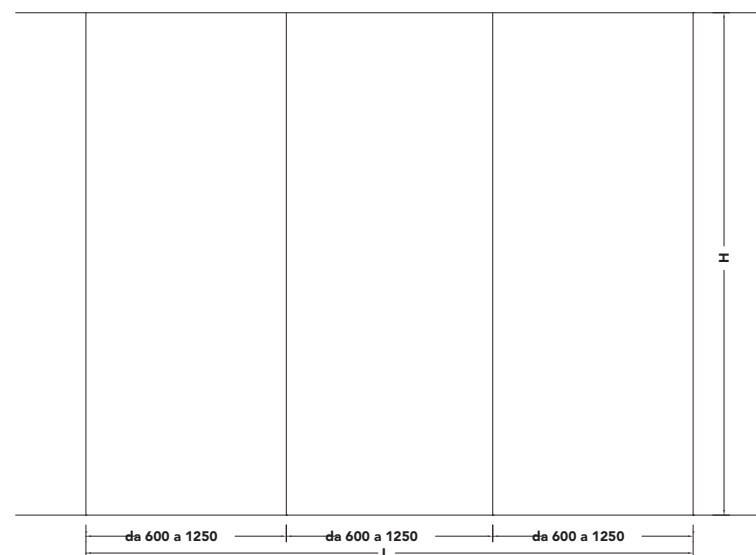
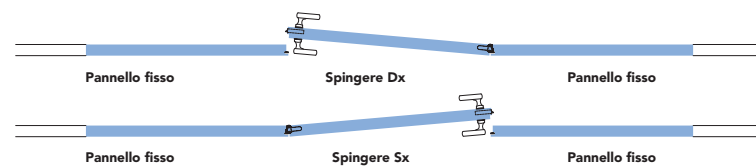

## wall & door

Sistema costituito da pannelli fissi ed apribili realizzati su misura, entrambi prevedono una struttura tamburata di spessore 55 mm, finitura laccato lucido o opaco o impiallacciata verticalmente in essenze di serie. Impiallacciatura orizzontale solo su richiesta. Completa di ferramenta, cerniere a scomparsa.

Wall system made of custom sizes fixed and swing opening panels. Hollow core construction 55 mm thick. Finishes available: wood veneer, matte and glossy lacquer.

**L**  
Larghezza pannello  
Panel width  
cm 60 - 125 23 5/8" - 49 1/4"

**H**  
Altezza max pannello  
Max panel height  
max cm 300 118 1/4"

wall & door compass / offset door

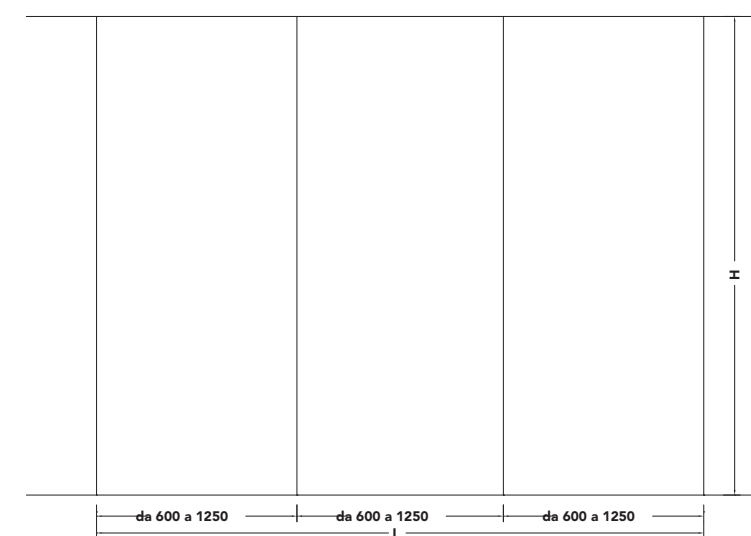
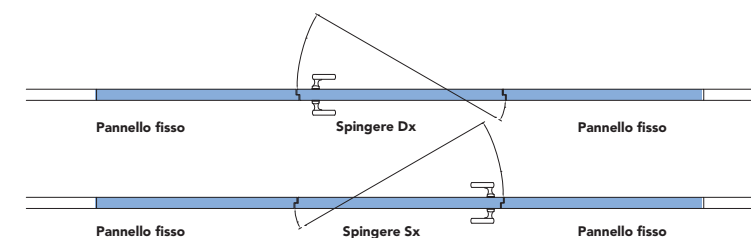

**L**  
Larghezza pannello  
Panel width  
cm 60 - 125 23 5/8" - 49 1/4"

**H**  
Altezza max pannello  
Max panel height  
max cm 300 118 1/4"



## Outline —

disegnata da Erik Morvan, offre allo sguardo un volume puro, una superficie tridimensionale, vero e proprio elemento architettonico in grado di definire lo spazio. Fra i vantaggi tecnici: si monta direttamente su parete a lavori finiti, è realizzabile su misura in diverse altezze, ed è disponibile anche in versione con cover, con coprifili sul lato esterno.

Designed by Erik Morvan, the pure volume and three-dimensional surface create a piece of architecture able to lend definition to a space.

It is mounted directly onto the wall and available in a variety of heights. With the cover version the casings are on the outside.











Punto di forza di Outline è la combinazione di misure e dimensioni: la larghezza dell'anta e l'altezza variabile, da 210 fino a 300 centimetri.

One of the strengths of Outline is the variety of dimensions available for the door width and the height, which can vary from 210 cm to 300 cm.

**Outline** \_094







L'impiallacciatura verticale del rovere tinto grigio si legge come una texture elegantemente naturale.

The vertical veneer of the grey tinted oak creates an elegantly natural texture.

**Outline**\_097

# Out line



outline

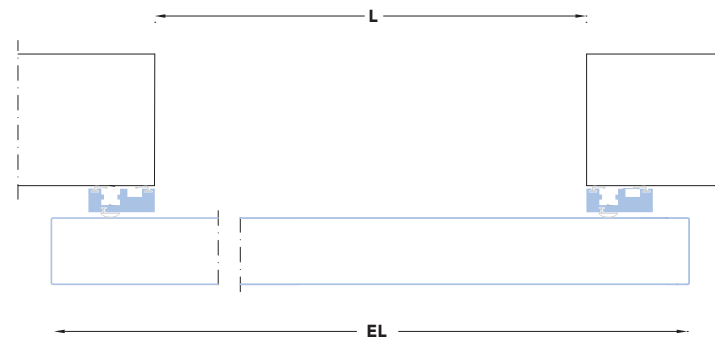

outline con cover / with cover

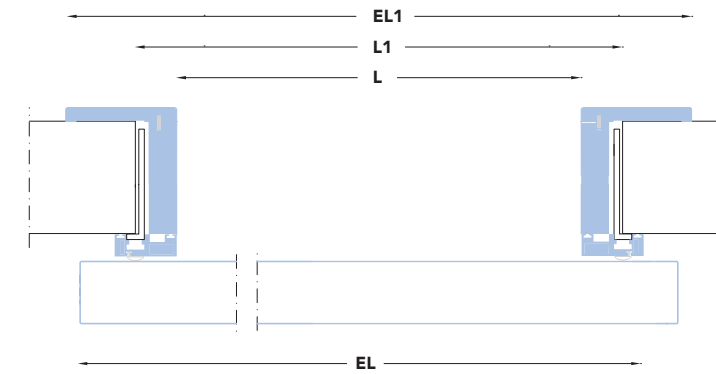

pag. 090 – 091  
 laccato bianco lucido  
 / white gloss lacquer  
 pag. 092 – 093 – 094 – 095  
 laccato rosso lucido  
 / red gloss lacquer  
 pag. 096 – 097  
 rovere grigio / grey oak

## Outline

Porta a battente in tamburato.  
 Bordi a sezione squadrata.  
 Battente in rovere (sbiancato, moka, grigio), ebano, teak; laccato lucido e laccato opaco nei colori di serie. Telaio in alluminio per installazione diretta sulla parete. Cerniere pivotanti in acciaio. Guarnizione di battuta. Montaggio su vano muro presquadrato. Serratura orizzontale.

Hollow core hinged door.  
 Squared edges. Veneered in oak (bleached, moka, dark grey), ebony, teak, gloss and matte lacquer from standard color range. Aluminium frame for direct wall installation. Pivoting steel hinges. Horizontal lock. Installation on pre-squared wall. Door striker seal.

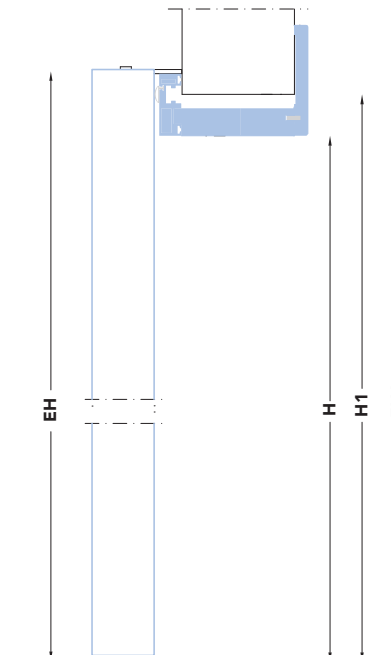
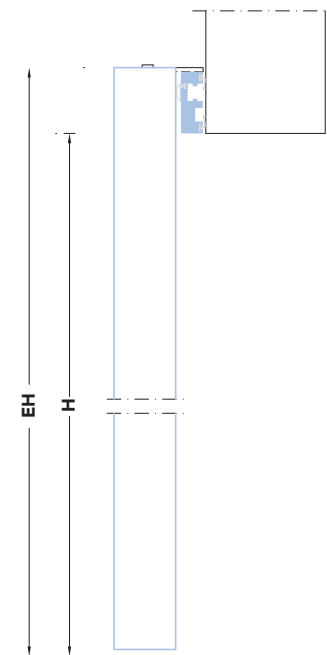

**L**  
 Larghezza luce netta  
 Opening width  
 cm 60 23 5/8"  
 cm 70 27 1/2"  
 cm 80 31 1/2"  
 cm 90 35 3/8"

**H**  
 Altezza luce netta  
 Opening height  
 cm 210-300 82 3/8"-118 1/4"

**EL - EH**  
 Ingombro anta  
 Door dimensions  
 cm 74x214,8-304,8 29 1/8"x 84 5/8"-120 1/8"  
 cm 84x214,8-304,8 33 1/8"x 84 5/8"-120 1/8"  
 cm 94x214,8-304,8 37" x 84 5/8"-120 1/8"  
 cm 104x214,8-304,8 41" x 84 5/8"-120 1/8"

**L**  
 Larghezza luce netta  
 Opening width  
 cm 60 23 5/8"  
 cm 70 27 1/2"  
 cm 80 31 1/2"  
 cm 90 35 3/8"

**H**  
 Altezza luce netta  
 Opening height  
 cm 210-300 82 3/8"-118 1/4"

**EL - EH**  
 Ingombro anta  
 Door dimensions  
 cm 74x214,8-304,8 29 1/8"x 84 5/8"-120 1/8"  
 cm 84x214,8-304,8 33 1/8"x 84 5/8"-120 1/8"  
 cm 94x214,8-304,8 37" x 84 5/8"-120 1/8"  
 cm 104x214,8-304,8 41" x 84 5/8"-120 1/8"

**L1 - H1**  
 Misura al grezzo  
 rough opening  
 cm 66x213-303 26" x 83 7/8"-119 3/8"  
 cm 76x213-303 29 7/8"x 83 7/8"-119 3/8"  
 cm 86x213-213 33 1/8"x 83 7/8"-119 3/8"  
 cm 96x213-303 37 3/4"x 83 7/8"-119 3/8"

**EL1 - EH1**  
 Ingombro cover  
 Cover dimensions  
 cm 76x218-308 29 7/8"x 85 7/8"-121 3/8"  
 cm 86x218-308 33 7/8"x 85 7/8"-121 3/8"  
 cm 96x218-308 37 3/4"x 85 7/8"-121 3/8"  
 cm 106x218-308 41 1/4"x 85 7/8"-121 3/8"



## Drive —

può leggersi come bella superficie semplicemente appoggiata alla parete, questa anta scorrevole la cui tecnologia, completamente a scomparsa, permette di ottenere effetti di grande leggerezza. Il binario telescopico, in alluminio ossidato naturale o nero, si applica direttamente a parete.

This sliding door can be seen as a beautiful surface simply laid against the wall. The technology is totally invisible and creates an effect

of extraordinary lightness. The telescopic rail in natural or black anodized aluminium is applied directly to the wall.











La maniglia in acciaio satinato è un semplice segno verticale in perfetto accordo con la finitura del binario e il laccato lucido grigio dell'anta.

The handle in brushed steel is a simple vertical mark, in perfect harmony with the finish of the rail and the grey gloss lacquer of the door.



L'impiallacciatura verticale in palisandro, calda e decorativa, è associata al binario nero.

The warm and decorative vertical rosewood veneer is twinned with the black rail.

**Drive** \_ 106







# Drive

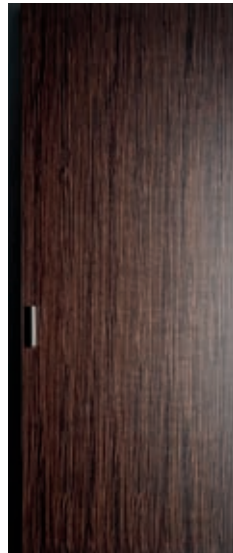

pag. 102 – 103 – 104 – 105  
 laccato grigio lucido  
 / grey gloss lacquer  
 pag. 106 – 107  
 palissandro / rosewood  
 pag. 109  
 laccato verde opaco  
 / green matte lacquer

## Drive

Porta scorrevole in tamburato.  
 Bordi a sezione quadrata.  
 Finiture dell'anta: essenza di rovere (sbiancato, moka, grigio), ebano, teak o laccato lucido e opaco nei colori di serie. Binario telescopico in alluminio per installazione diretta sulla parete. Finiture del binario: alluminio satinato o anodizzato nero. Montaggio su muro presquadrato.

Hollow core sliding door.  
 Squared edges. Finishes: oak (bleached, moka and dark grey), ebony, teak, polished and matte enamelled in range colours  
 Aluminum telescopic track for direct wall installation.  
 Track finishes: aluminium inox and black anodized aluminium.  
 Installation on pre-squared wall.

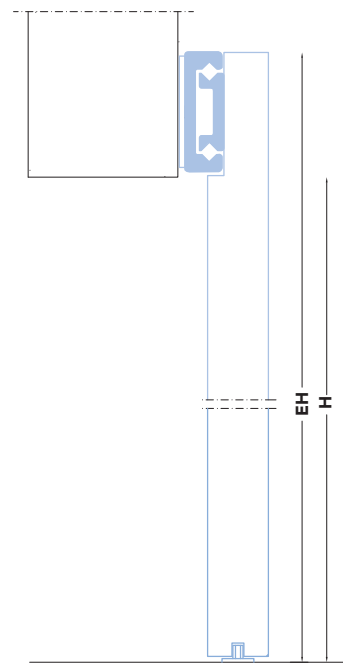

versione per muratura / brickwall

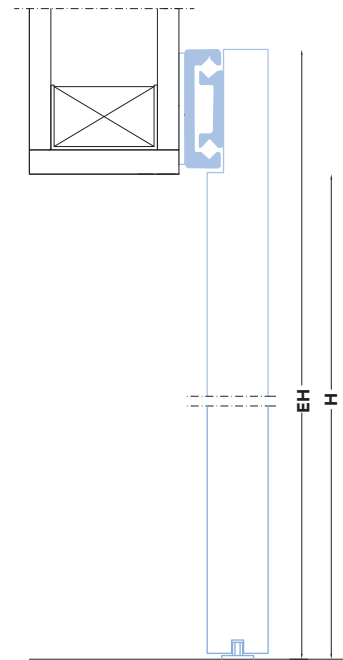

versione per cartongesso / drywall

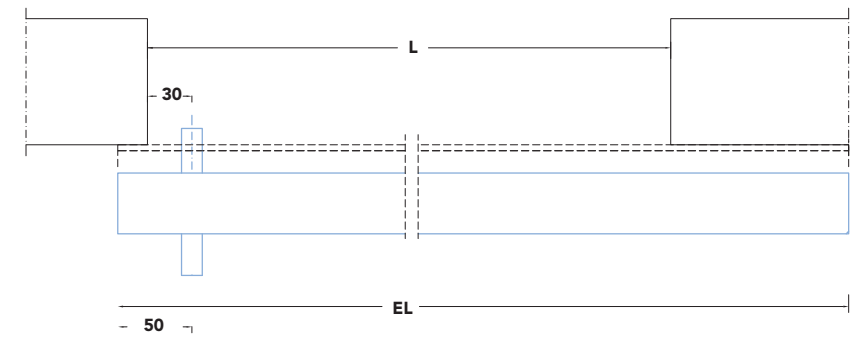
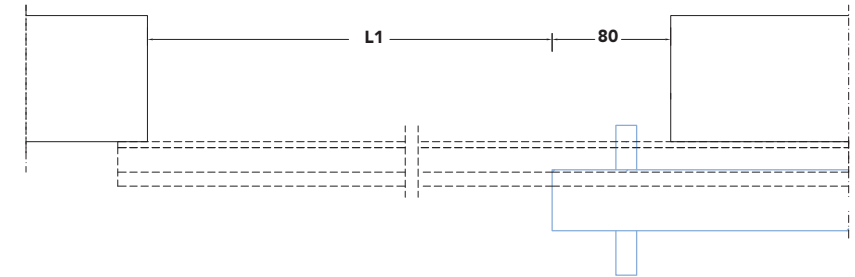

### L

Larghezza vano  
 Opening width  
 cm 70 27 1/2"  
 cm 80 31 1/2"  
 cm 90 35 3/8"

### L1

Luce netta passaggio  
 Net opening  
 cm 62 24 3/8"  
 cm 72 28 1/8"  
 cm 82 32"

### H

Altezza luce netta  
 Opening height  
 cm 210-300 82 5/8"-118 1/4"

### EL - EH

Ingombro esterno max  
 Max external dim.  
 cm 84x218,4-308,4 33" x85 5/8"-121 1/2"  
 cm 94x218,4-308,4 37" x85 5/8"-121 1/2"  
 cm 104x218,4-308,4 40 7/8"x85 5/8"-121 1/2"





Inspired by the light and extensive mobile surfaces of, the traditional Japanese house, Shoin is a system of one or two track, glass sliding doors and fixed panels, designed

to create walls. The panels are fixed within a slim aluminium frame, flush with the external side of the composition.

## Shoin —

ispirata alle ampie e leggere superfici mobili della casa tradizionale giapponese, Shoin è un sistema di ante scorrevoli e pannelli fissi in vetro, a uno o due binari, progettato per comporre pareti. Le lastre vivono all'interno di un sottile telaio in alluminio, a filo con il vetro sulla facciata esterna della composizione.







Composizione a due ante fisse e una mobile. Il telaio in alluminio verniciato nero è combinato con vetro fumé specchiato riflettente. La maniglia in acciaio è inserita nello spessore del vetro.

Composition of one mobile and two fixed doors. The brown aluminium frame is combined with smoky, mirrored glass. The steel handle is set within the thickness of the glass.







Composizione a due ante scorrevoli,  
con telaio in alluminio e vetro Rain grigio.

Composition with two sliding doors,  
with an aluminium frame and grey  
Rain glass.

**Shoin** \_ 120

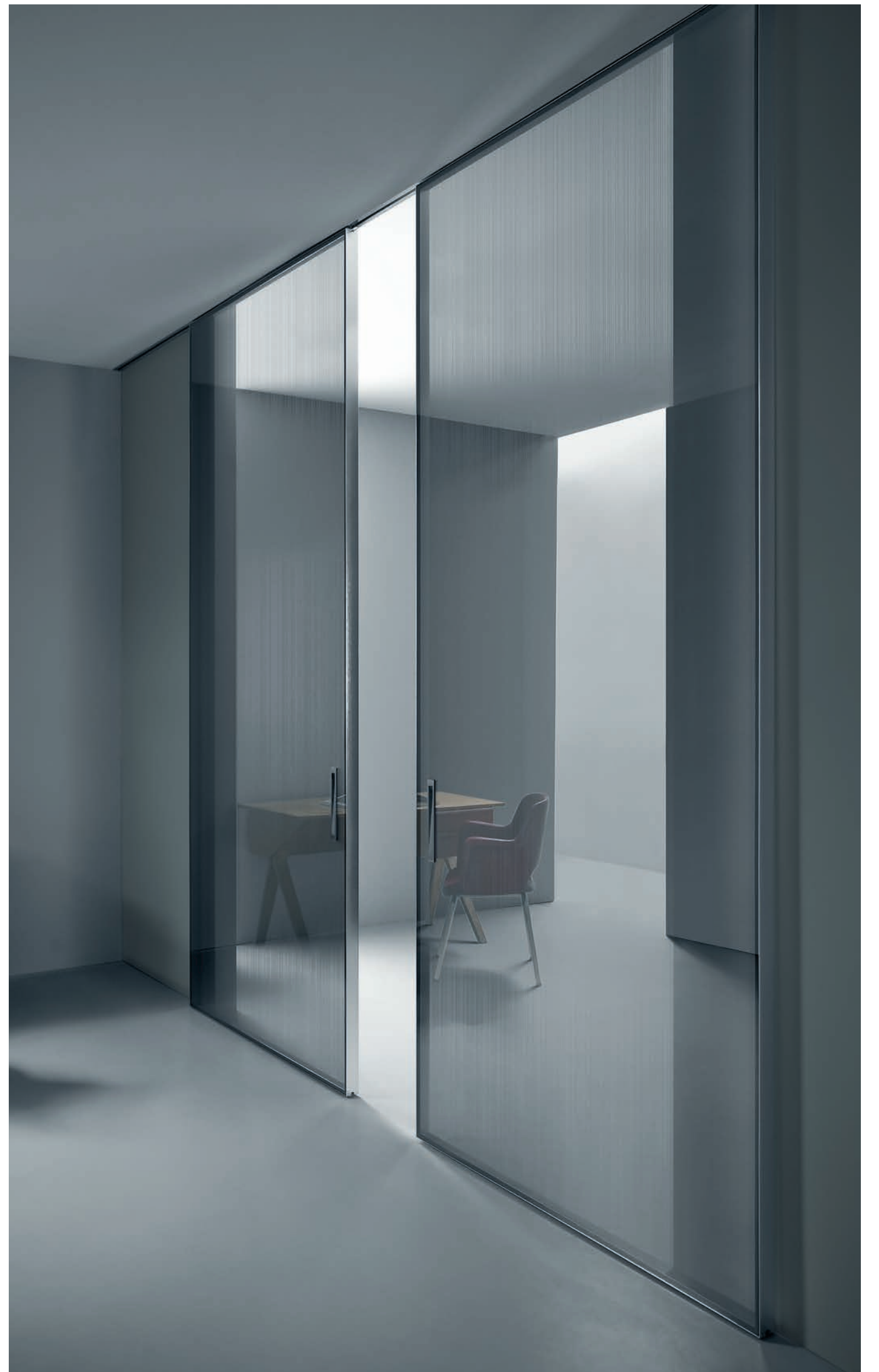







Shoin consente la creazione di veri e propri ambienti, luminose scatole di cristallo che definiscono con leggerezza spazi negli spazi.

Shoin allows for the creation of veritable environments, luminous glass boxes to lightly delineate spaces within spaces.

La riuscita estetica di Shoin, anche nei sistemi più complessi e articolati, è il risultato di soluzioni funzionali ad alta tecnologia.

Highly technological functional solutions, even in the most complex systems, are the key to the aesthetic success of Shoin.





# Sho in

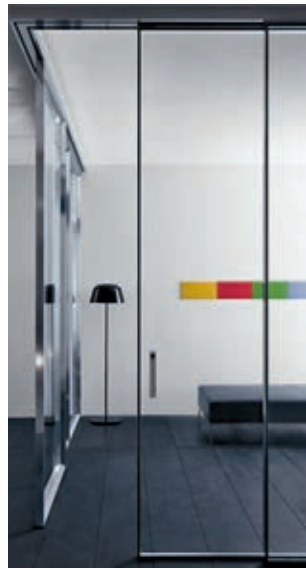

pag. 114 – 115 – 116 – 117 – 119  
 vetro grigio trasparente / grey transparent glass  
 pag. 120 – 121  
 vetro grigio rain / grey rain glass  
 pag. 122 – 123 – 124 – 125 – 127  
 vetro trasparente / transparent glass

## Shoin

Sistema di ante fisse e scorrevoli con spessore mm 50 realizzate su misura. Ante in vetro di sicurezza spessore mm 6 finiture di serie. Telaio di contenimento in alluminio finiture di serie. Binario ad una o due vie, sistema di freno decelerante. Meccanismo di regolazione in altezza nascosto nel carrello del binario.

Sliding door with ceiling tracks  
 Laminated glass door panel,  
 6 mm. thick. Glass finishes:  
 transparent, opal, bronzed,  
 grey, rain. Aluminium frame.  
 Height adjustment mechanism  
 hidden in track.

**L**  
 Max  
 mm. 1200 47 1/4"

## binario singolo / single track

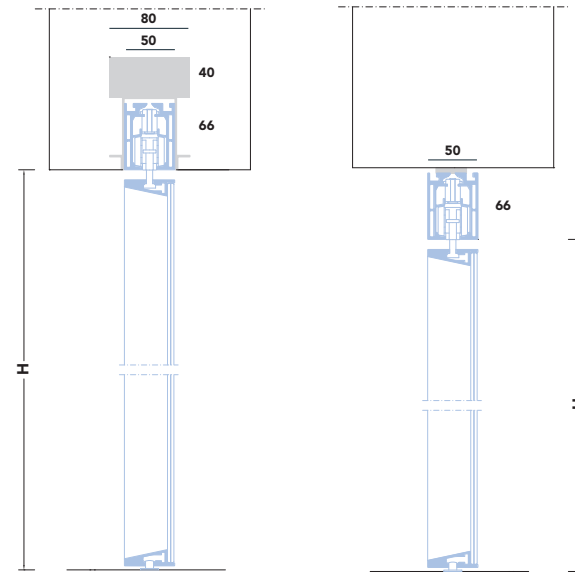

## binario doppio / double track

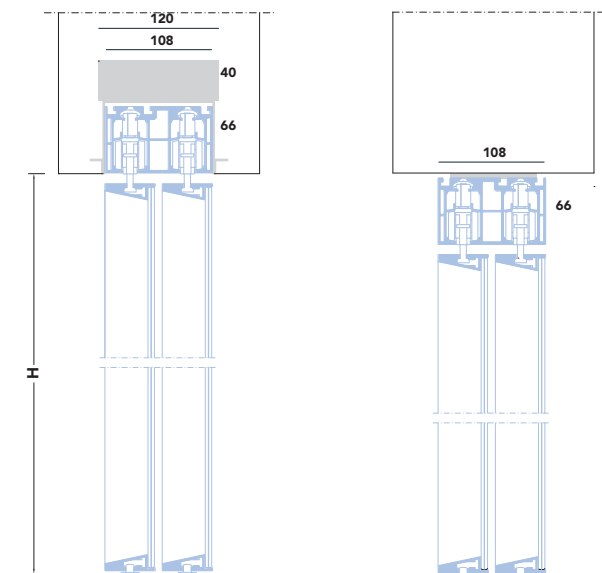

## anta singola esterno muro / external single door leaf

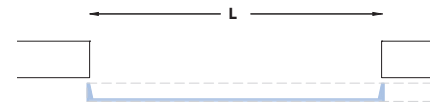

## Due ante interno muro / internal double door leaves



## Due ante esterno muro / external double door leaves

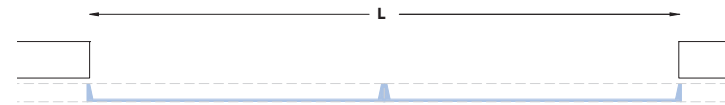

## Quattro ante interno muro / internal four door leaves

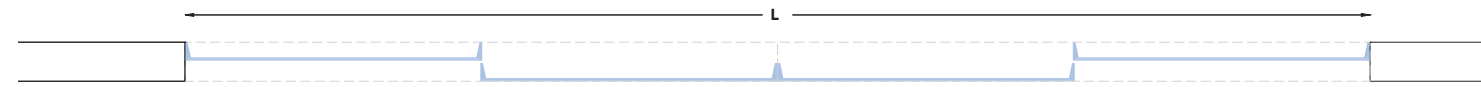

**H**  
 Max  
 mm. 300 118 1/4"

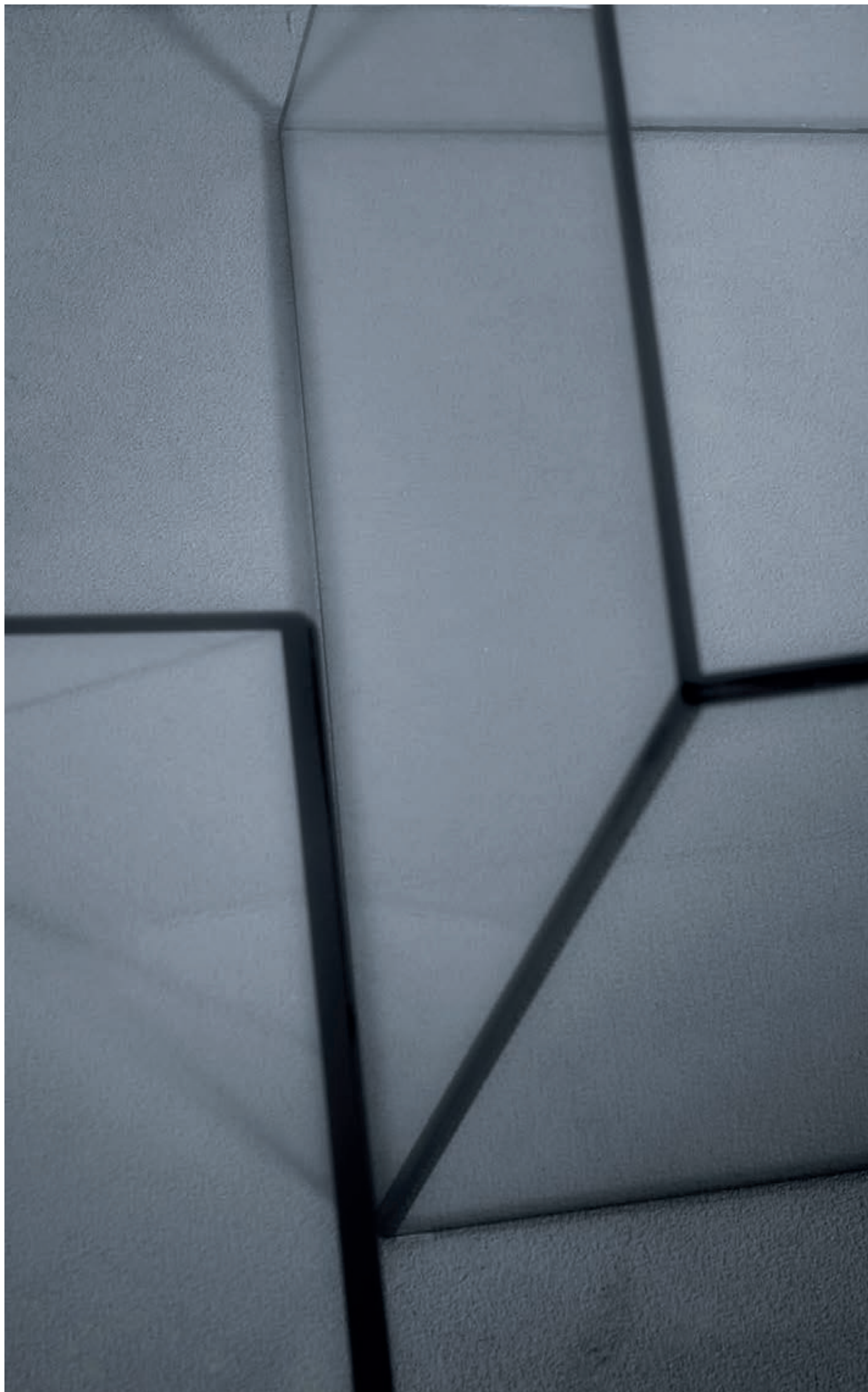

With the frame and walls perfectly flush, the slim line blends with the purity of the surfaces. The reversed edge and the opening to the interior confer an stylish effect of continuity

with the sides of the corridor. Available in the new elegant finishes, it is versatile and adapts to solid wall, plasterboard and moveable wall systems.

## Filo \_

perfettamente complanare a stipite e parete, associa alla purezza della superficie una linea slanciata.

Grazie alla battuta rovesciata e all'apertura verso l'interno, ottiene un elegante effetto di continuità con i lati del corridoio. Disponibile nelle nuove eleganti finiture, ha natura versatile e si adatta a muratura, cartongesso e sistemi di pareti mobili.



Perfettamente complanare, Filo ottiene un elegante effetto di continuità con le superfici del corridoio.

Perfectly flush, Filo creates an elegant effect of continuity with the surfaces of the corridor.

Filo \_\_ 132















In essenza noce canaletto, contraddistinta da una luminosità naturale, Filo si presta bene ad ambienti di gusto classico.

With a black walnut finish and distinguished by a natural luminosity, Filo lends itself well to classical environments.

Filo \_\_141

# Filo \_s



pag. 133 – 134 – 135  
laccato bianco opaco  
/ white matte lacquer  
pag. 136 – 137  
laccato bianco lucido  
/ white gloss lacquer  
pag. 139 – 140 – 141  
noce canaletto  
/ dark walnut

## Filo s-t

Porta a battente in tamburato, spessore 55mm. Battente, stipite e coprifili in laccato opaco nei colori di serie e in essenze. Versione Lux con vetro opalino. Sistema telescopico dello stipite da 10cm a 12cm. Guarnizione di battuta. Cerniere a scomparsa. Montaggio su falsi telai tradizionali in legno.

Hollow-core hinge door, thickness 55mm. Door panel, jamb and casing in matte lacquer in standard colours and in wood with opal glass in the Lux version. Door jamb adjustable from 10cm to 12cm. Door striker seal. Concealed hinges. Mounted on traditional wood subframe.

**L**  
Larghezza luce netta  
Opening width  
cm 60 23 5/8"  
cm 70 27 1/2"  
cm 80 31 1/2"  
cm 90 35 3/8"

**H**  
Altezza luce netta  
Opening height  
cm 210-300 82 5/8" - 118 1/4"

**L1**  
Larghezza falso telaio  
Subframe width  
cm 70 27 1/2"  
cm 80 31 1/2"  
cm 90 35 3/8"  
cm 100 38 3/4"

**H1**  
Altezza falso telaio  
Subframe height  
cm 215-305 84 1/2"-120"

## filo s apertura a spingere / push opening

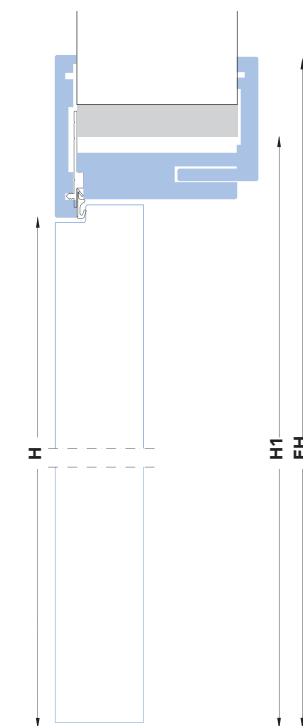
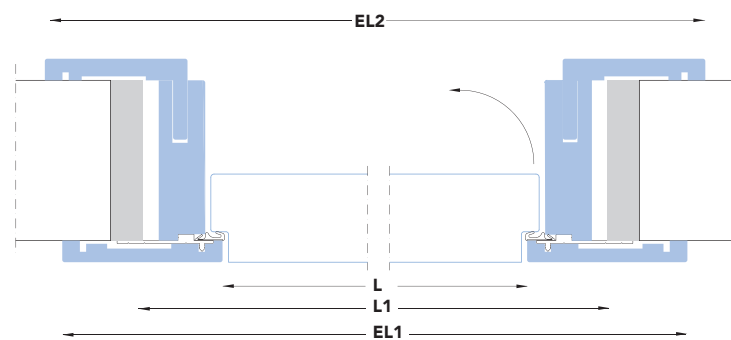

**EH**  
Ingombro esterno max  
Max external dimensions  
cm 220-310 86 7/8"-122"

**EL1**  
Ingombro esterno  
External dimensions  
cm 80 31 1/2"  
cm 90 35 3/8"  
cm 100 38 3/4"  
cm 110 43 1/4"

**EL2**  
Ingombro esterno max  
Max external dimensions  
cm 82,2 32 1/8"  
cm 92,2 36"  
cm 102,2 40"  
cm 112,2 43"

# Filo \_t

## filo t apertura a tirare / pull opening

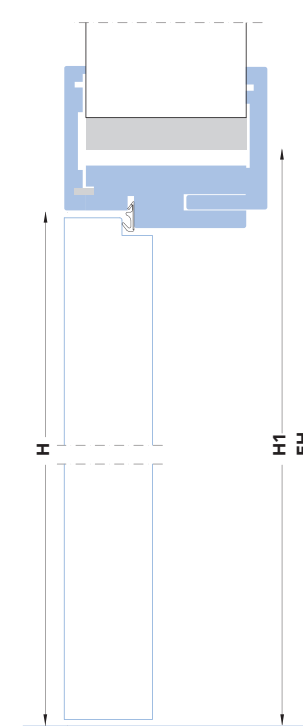
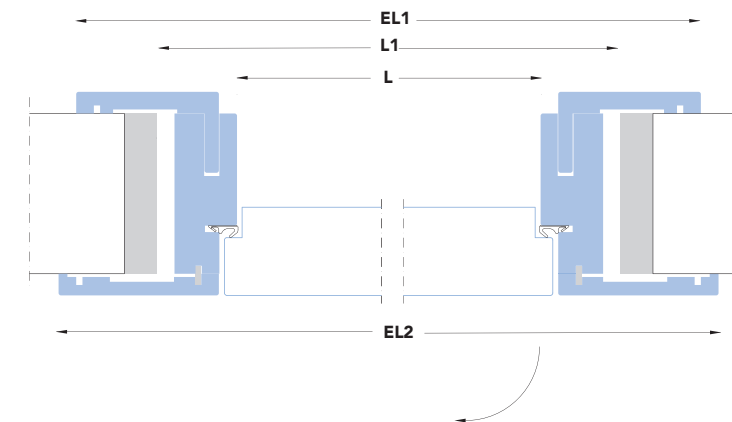

**L**  
Larghezza luce netta  
Opening width  
cm 60 23 5/8"  
cm 70 27 1/2"  
cm 80 31 1/2"  
cm 90 35 3/8"

**H**  
Altezza luce netta  
Opening height  
cm 210-300 82 5/8" - 118 1/4"

**L1**  
Larghezza falso telaio  
Subframe width  
cm 70 27 1/2"  
cm 80 31 1/2"  
cm 90 35 3/8"  
cm 100 38 3/4"

**H1**  
Altezza falso telaio  
Subframe height  
cm 215-305 84 1/2"-120"

**EH**  
Ingombro esterno max  
Max external dim.  
cm 220-310 86 7/8"-122"

**EL1**  
Ingombro esterno max  
Max external dim.  
cm 80 31 1/2"  
cm 90 35 3/8"  
cm 100 38 3/4"  
cm 110 43 1/4"

**EL2**  
Ingombro esterno max  
Max external dim.  
cm 82,2 32 1/8"  
cm 92,2 36"  
cm 102,2 40"  
cm 112,2 43 7/8"

# Filo Touch

## S

filo touch s apertura a spingere / push opening

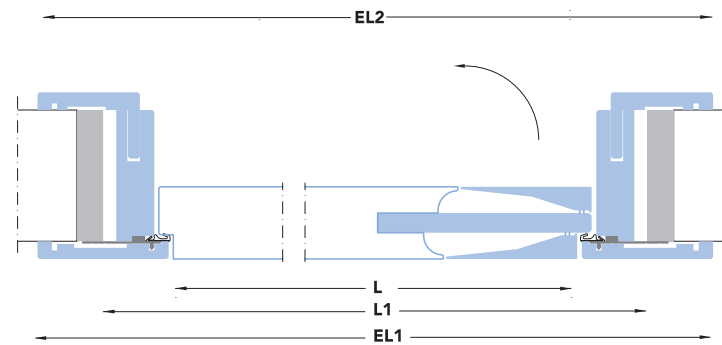

filo touch t apertura a tirare / pull opening

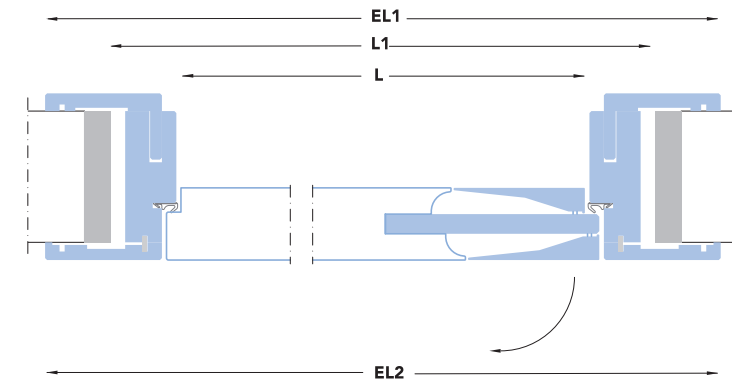

# Filo Touch

## t

### Filo touch s-t

Anta con maniglia a scomparsa, l'apertura è ottenuta con pressione della fascia verticale. Battente laccato opaco, lucido o in essenza di serie. Fascia a pressione sempre laccata colore opaco.

Swinging wood door with a concealed incorporated handle. The handle operates by pressing the vertical band. Factory pre-finish available in matt and polished lacca as well as Lualdi's standard wood veneers. (Handle's vertical band always lacquered in opaque color) Wood jambs.

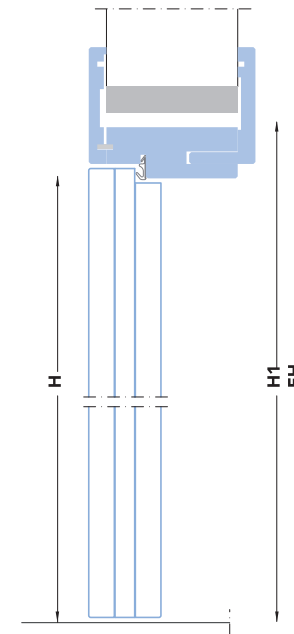
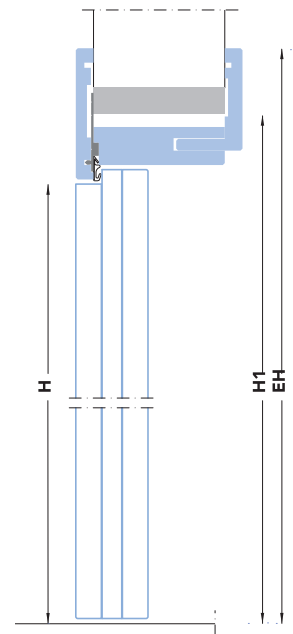

**L**  
Larghezza luce netta  
Opening width  
cm 60 23 5/8"  
cm 70 27 1/2"  
cm 80 31 1/2"  
cm 90 35 3/8"

**H**  
Altezza luce netta  
Opening height  
cm 210-300 82 5/8" - 118 1/4"

**EH**  
Ingombro esterno max  
Max external dimensions  
cm 220-310 86 7/8"-122"

**L1**  
Larghezza falso telaio  
Subframe width  
cm 70 27 1/2"  
cm 80 31 1/2"  
cm 90 35 3/8"  
cm 100 38 3/4"

**H1**  
Altezza falso telaio  
Subframe height  
cm 215-305 84 1/2"-120"

**EL1**  
Ingombro esterno  
External dimensions  
cm 80 31 1/2"  
cm 90 35 3/8"  
cm 100 38 3/4"  
cm 110 43 1/4"

**EL2**  
Ingombro esterno max  
Max external dimensions  
cm 82,2 32 1/8"  
cm 92,2 36"  
cm 102,2 40"  
cm 112,2 43"

**L**  
Larghezza luce netta  
Opening width  
cm 60 23 5/8"  
cm 70 27 1/2"  
cm 80 31 1/2"  
cm 90 35 3/8"

**H**  
Altezza luce netta  
Opening height  
cm 210-300 82 5/8"- 118 1/4"

**EH**  
Ingombro esterno max  
Max external dim.  
cm 220-310 86 7/8"-122"

**L1**  
Larghezza falso telaio  
Subframe width  
cm 70 27 1/2"  
cm 80 31 1/2"  
cm 90 35 3/8"  
cm 100 38 3/4"

**H1**  
Altezza falso telaio  
Subframe height  
cm 215-305 84 1/2"-120"

**EL1**  
Ingombro esterno max  
Max external dim.  
cm 80 31 1/2"  
cm 90 35 3/8"  
cm 100 38 3/4"  
cm 110 43 1/4"

**EL2**  
Ingombro esterno max  
Max external dim.  
cm 82,2 32 1/8"  
cm 92,2 36"  
cm 102,2 40"  
cm 112,2 43 7/8"



## Lcd62 —

un modello storico riproposto in un'evoluzione che coinvolge tecnica ed estetica. A renderne più flessibili gli usi sono l'anta reversibile, la cerniera a scomparsa e il telaio telescopico, grazie a cui il modello si adatta a diversi spessori di muratura. Le rivisitate proporzioni della cornice e le nuove finiture, accendono la linea classica di note contemporanee.

An historic model that has evolved both technically and aesthetically. The reversible door, the concealed hinge and the adjustable door jamb which adapts to a variety of wall

thicknesses, all allow more flexibility in the range of uses. The revised proportions of the frame and the new finishes lend a contemporary note to the classical line.

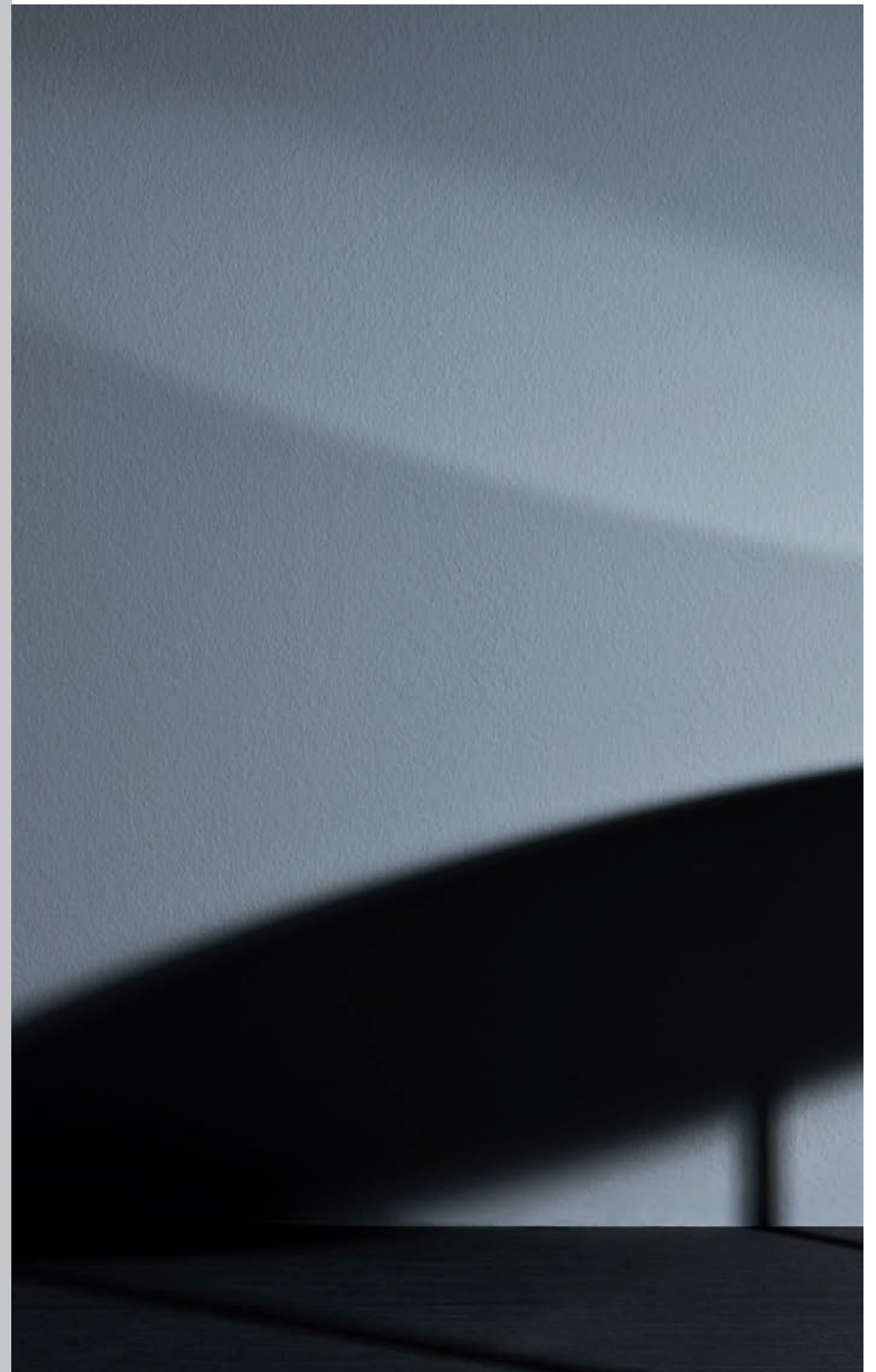



Lcd62, qui nella finitura rovere moka,  
è disponibile anche in altre essenze  
e in laccato opaco nei nuovi colori.

Lcd62, here with a mocha oak finish  
is also available in other wood veneers  
and matte lacquered in the new  
colours.





Design pulito per la maniglia Push and Pull, in nichel satinato, prodotta in esclusiva per Lualdi.

A neat design for the Push and Pull handle, in brushed nickel and produced exclusively for Lualdi.

**Lcd62** \_\_ 150







Due Lcd62 a tutta altezza in laccato opaco bianco, per un effetto spaziale di slancio e ritmo armonico.

Two full height Lcd62 in white matte lacquer creating a spatial effect of energy and harmonic rhythm.

Lcd62 \_\_152







Dettaglio dello stipite esterno, interno  
e della battuta con guarnizione.

Detail of the external and internal  
sides of the doorjamb.



# lcd 62

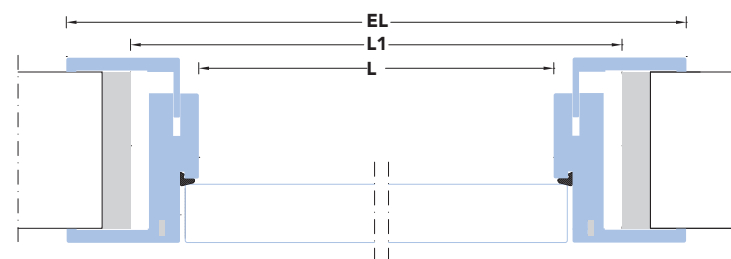

pag. 148 – 150 – 151  
rovere moka / mocha oak  
pag. 152 – 153  
154 – 155 – 156 – 157  
laccato opaco bianco  
/ white matte lacquer

## lcd62

Porta a battente in tamburato, spessore 41mm. Battente, stipite e coprifili in laccato opaco nei colori di serie, essenza di rovere (sbiancato, moka, grigio).  
Versione Lux con vetro opalino  
Sistema telescopico dello stipite: da 9,5 a 12cm e da 12,5 a 15cm.  
Guarnizione di battuta.  
Reversibilità del senso di apertura.  
Cerniere a scomparsa. Montaggio su falsi telai tradizionali in legno.  
Disponibile anche in versione scorrevole esterna o a scomparsa.

Hollow-core hinge door, thickness 41mm. Door panel, jamb and casing in matte lacquer in standard colours and in oak (bleached, mocha, grey). Lux version with opal glass. Door jamb adjustable from 9.5 to 12 cm and from 12.5 to 15 cm. Door striker seal. Reversible opening. Concealed hinges. Mounted on traditional wood subframe. Also available in pocket and surface mounted sliding versions.

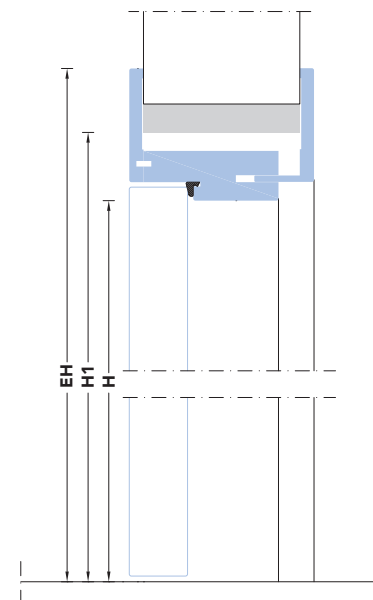

### L

Larghezza luce netta  
Opening width  
cm 60 23 5/8"  
cm 70 27 1/2"  
cm 80 31 1/2"  
cm 90 35 3/8"

### L1

Larghezza falso telaio  
Subframe width  
cm 70 27  
cm 80 30 7/8"  
cm 90 34 7/8"  
cm 100 38 3/4"

### H

Altezza luce netta  
Opening height  
cm 210-300 82 5/8"-118 1/4"

### H1

Altezza falso telaio  
Subframe height  
cm 215-305 84 1/2"-120"

### EH

External dim.  
cm 219-309 86 1/4"-121 3/4"

### EL

Ingombro esterno max  
Max external dim.  
cm 78 30 3/4"  
cm 88 34 5/8"  
cm 98 38 5/8"  
cm 108 42 1/2"

## San Siro\_

disegnata da Luigi Caccia Dominioni, recupera le forme della tradizione, interpretandone lo spirito classico in chiave moderna. Il gioco di proporzioni e il disegno delle fasce laterali introducono un elemento di lieve dissonanza in una composizione di grande misura, fatta per abitare con facilità ogni tipo di spazio.

Designed by Luigi Caccia Dominioni, this recuperation of the traditional form interprets the classic spirit with a modern tone. The play of proportions and the design

of the side strips introduce a lightly dissonant element into a composition of great dimension, created to fit easily into any type of space.









Dettaglio della maniglia Lualdi in cromo satinato, su finitura bianco laccato opaco. Lo stipite è dotato di guarnizione in gomma.

Detail of the brushed chrome Lualdi handle on a white matte lacquer finish. The doorjamb is furnished with rubber sealing.



# San Siro

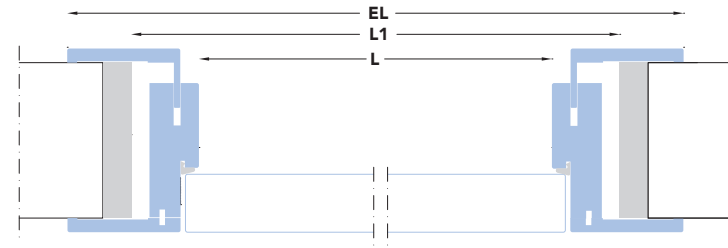

pag. 162 – 163  
– 164 – 165 – 166  
laccato opaco bianco  
/ white matte lacquer

## San Siro

Porta a battente in tamburato, spessore mm 41, con specchiature incassate. Battente e stipite laccato opaco nei colori di serie. Sistema telescopico dello stipite da 9,5 a 12 cm e da 12,5 a 15 cm. Guarnizione di battuta. Reversibilità del senso di apertura. Cerniere a scomparsa. Montaggio su falsi telai tradizionali in legno. Disponibile anche in versione scorrevole esterna o a scomparsa.

Hollow core hinged door, 41 mm thick, with recessed symmetric panels. Door panel and jamb in matte finish from standard color range. Telescopic doorjamb: from 9.5 to 12 cm and from 12.5 to 15 cm. Door striker seal. Reversible opening direction. Concealed hinges. Mounted on traditional wooden subframe. Pocket or external sliding versions also available.

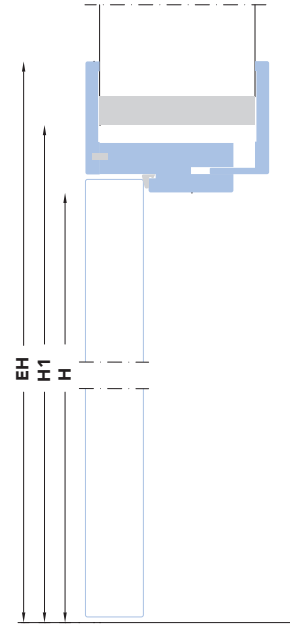

### L

Larghezza luce netta  
Opening width  
cm 60 23 5/8"  
cm 70 27 1/2"  
cm 80 31 1/2"  
cm 90 35 3/8"

### L1

Larghezza falso telaio  
Subframe width  
cm 70 27  
cm 80 30 7/8"  
cm 90 34 7/8"  
cm 100 38 3/4"

### H

Altezza luce netta  
Opening height  
cm 210 82 5/8"

### H1

Altezza falso telaio  
Subframe height  
cm 215 84 1/2"

### EH

External dim.  
cm 219 86 1/4"

### EL

Ingombro esterno max  
Max external dim.  
cm 78 30 3/4"  
cm 88 34 5/8"  
cm 98 38 5/8"  
cm 108 42 1/2"



Ala \_

il coprifilo dalla caratteristica forma e l'anta con intarsi orizzontali in acciaio inox fanno di Ala, disegnata da Erik Morvan, un modello ricercato, capace di originali e delicate suggestioni. Sulla parete, lo sfumato gioco d'ombra creato dal bordo conferisce alla superficie tridimensionalità e volume.

The softened edges of the casing and the door with horizontal etching in stainless steel make Ala, designed by Erik Morvan, a greatly sort after model, capable of creating original

and delicate solutions. On the wall, the mellow shadow effect created by the edging lends volume and a three-dimensional effect to the surface.









Il coprifilo e l'inserto in acciaio inox:  
dettagli preziosi realizzati con la cura  
e la qualità di un lavoro di ebanisteria.  
La finitura è laccato opaco bianco 101.

The softened forms of the casing and  
the insert in stainless steel are important  
details realized with the care and quality  
of a cabinet maker. The finish is 101  
chalk white matte lacquer.

**Ala** \_174





# Ala



pag. 172 – 173  
rovere moka / mocha oak  
pag. 174 – 175  
laccato opaco bianco  
/ white matte lacquer

## Ala

Porta a battente in tamburato, spessore mm 41. Battente con inserti in acciaio inox, finiture in rovere (sbiancato, moka, grigio) impiallacciato orizzontale; laccato opaco. Versione Lux con vetro opalino. Stipite e coprifili nelle stesse finiture. Sistema telescopico dello stipite: da 9,5 a 12 cm e da 12,5 a 15 cm. Cerniere a scomparsa. Guarnizione di battuta. Reversibilità del senso di apertura. Montaggio su falsi telai tradizionali in legno. Disponibile anche in versione scorrevole esterna o a scomparsa.

Hollow core hinged door, 41 mm thick. Door panel with stainless steel inlays, finishes in horizontal oak veneer or matte lacquer. Lux version features opal glass. Jamb and trim with matching finish. Telescopic door jamb: from 9.5 to 12 cm and from 12.5 to 15 cm. Concealed hinges. Door striker seal. Reversible opening direction. Mounted on traditional wooden subframe. Available also in pocket and external sliding versions.

## L

Larghezza luce netta  
Opening width  
cm 60 23 5/8"  
cm 70 27 1/2"  
cm 80 31 1/2"  
cm 90 35 3/8"

## L1

Larghezza falso telaio  
Subframe width  
cm 68,5 27"  
cm 78,5 30 7/8"  
cm 88,5 34 7/8"  
cm 98,5 38 3/4"

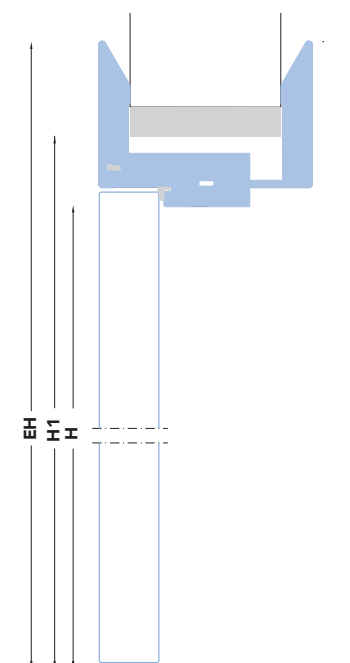
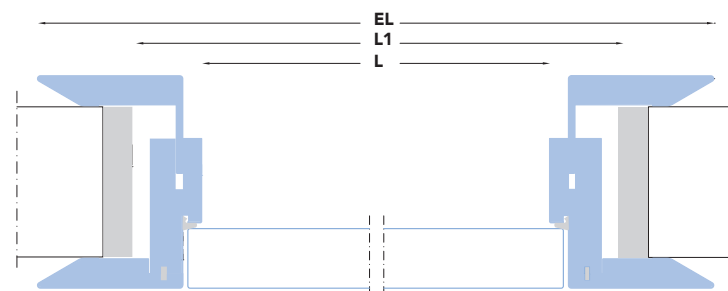

## H

Altezza luce netta  
Opening height  
cm 210-300 82 5/8"-118 1/4"

## H1

Altezza falso telaio  
Subframe height  
cm 214,5-304,5 84 1/2"-120"

## EL - EH

Ingombro esterno max  
Max external dim.  
cm 82,6x221,3-311,3 32 1/4"x87 1/4"-122 5/8"  
cm 92,6x221,3-311,3 36 1/4"x87 1/4"-122 5/8"  
cm 102,6x221,3-311,3 40 1/8"x87 1/4"-122 5/8"  
cm 112,6x221,3-311,3 44 3/8"x 87 1/4"-122 5/8"



## Kyoto —

una presenza originale capace di valorizzare lo spazio per la linea sofisticata, creata dal contrasto fra l'effetto di profondità dello stipite in alluminio di gusto high tech e la perfetta complanarità di parete e anta. Raffinate anche le finiture in essenza, laccato opaco e laccato lucido. Kyoto è disponibile anche con rivestimento in cuoio pieno fiore, bianco o naturale, proposto in una texture di bellezza essenziale, ispirata agli arredi giapponesi. Bartoli Design.

Forming an original presence, it enhances the space through its sophisticated line created by the contrast between the depth of the aluminium door jamb and the flushness of the wall and door.

---

The finishes in wood, matte and gloss lacquer are especially refined. Kyoto is also available with a white or natural full-grain leather covering inspired by Japanese furnishings with a texture of essential beauty. Bartoli Design

---











La texture astratta creata dal ritmo irregolare delle strisce in pelle ben si combina con l'essenziale design della maniglia.

The abstract texture created by the irregular rhythm of the leather stripes combines perfectly with the essential design of the handle.

**Kyoto** \_182





Dettaglio dello stipite in alluminio:  
una pelle high tech che corre lungo  
tutto il perimetro.

Detail of the doorframe in aluminium:  
high-tech leather edges the entire  
length of the perimeter.





# Kyoto



versione per muratura / brickwall

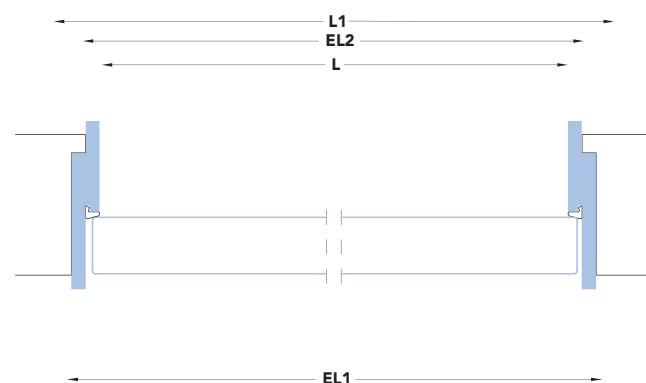

versione per cartongesso / drywall

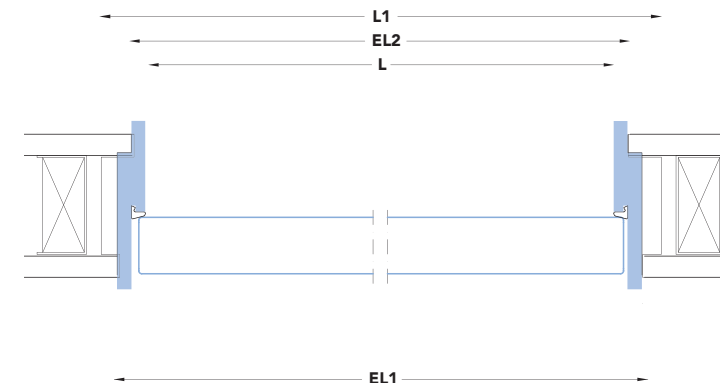

pag. 180 – 182 – 183  
 pelle bianca  
 / white leather  
 pag. 184 – 185  
 ocra / ochre  
 pag. 186  
 rovere grigio scuro  
 / dark grey oak

## Kyoto Bartoli Design

Porta a battente in tamburato, spessore 41mm. Battente laccato opaco, lucido, in essenza o in cuoio pienofiore. Stipite telescopico in alluminio per tavolati con spessore da 10 a 12 cm. Guarnizioni di battuta. Cerniere a scomparsa. Montaggio su falso telaio in lamiera zincata.

Hollow-core hinge door, thickness 41mm. Door panel with matte or gloss lacquer, wood or full-grain leather. Adjustable door jamb in aluminium for panels from 10 cm to 12cm in thickness. Door striker seal. Concealed hinges. Mounted on zinc laminate subframe.

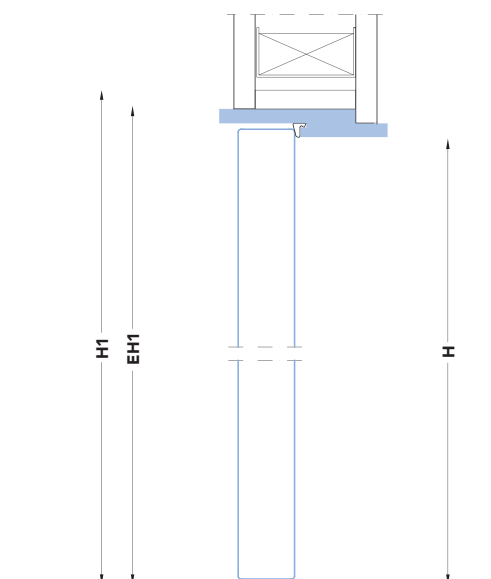
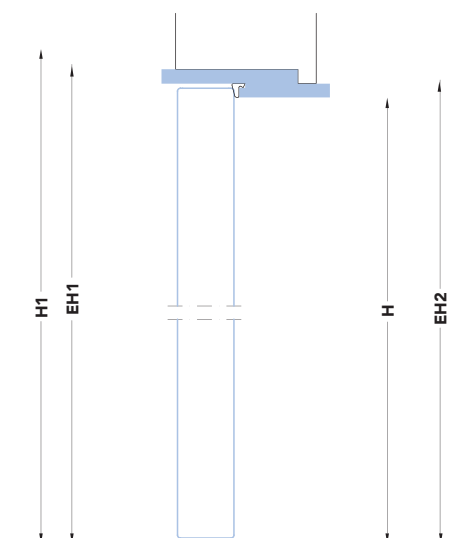

**L**  
 Larghezza luce netta  
 Opening width  
 cm 60 23 5/8"  
 cm 70 27 1/2"  
 cm 80 31 1/2"  
 cm 90 35 3/8"

**L1-H1**  
 Ingombro falso telaio  
 Subframe dimensions  
 cm 63,8x211,9-301,9 25 1/8"x83 3/8"-118 7/8"  
 cm 73,8x211,9-301,9 29 1/8"x83 3/8"-118 7/8"  
 cm 83,8x211,9-301,9 33" x83 3/8"-118 7/8"  
 cm 93,8x211,9-301,9 36 7/8"x83 3/8"-118 7/8"

**H**  
 Altezza luce netta  
 Opening height  
 cm 210-300 82 5/8"-118 1/4"

**EL1 - EH1**  
 Ingombro max esterno stipite  
 Frame max external dimensions  
 cm 65x212,5-302,5 25 5/8"x83 3/8"-119 1/8"  
 cm 75x212,5-302,5 29 5/8"x83 3/8"-119 1/8"  
 cm 85x212,5-302,5 33 5/8"x83 3/8"-119 1/8"  
 cm 95x212,5-302,5 37 5/8"x83 3/8"-119 1/8"

**EL2 - EH2**  
 Ingombro stipite  
 Frame external dimensions  
 cm 63x211,5-301,5 24 7/8"x83 3/8"-118 3/4"  
 cm 73x211,5-301,5 28 5/8"x83 3/8"-118 3/4"  
 cm 83x211,5-301,5 32 3/4"x83 3/8"-118 3/4"  
 cm 93x211,5-301,5 37 1/2"x83 3/8"-118 3/4"

**L**  
 Larghezza luce netta  
 Opening width  
 cm 60 23 5/8"  
 cm 70 27 1/2"  
 cm 80 31 1/2"  
 cm 90 35 3/8"

**L1-H1**  
 Ingombro falso telaio  
 Subframe dimensions  
 cm 63,8x211,9-301,9 25 1/8"x83 3/8"-118 7/8"  
 cm 73,8x211,9-301,9 29 1/8"x83 3/8"-118 7/8"  
 cm 83,8x211,9-301,9 33" x83 3/8"-118 7/8"  
 cm 93,8x211,9-301,9 36 7/8"x83 3/8"-118 7/8"

**H**  
 Altezza luce netta  
 Opening height  
 cm 210-300 82 5/8"-118 1/4"

**EL1 - EH1**  
 Ingombro max esterno stipite  
 Frame max external dimensions  
 cm 65x212,5-302,5 25 5/8"x83 3/8"-119 1/8"  
 cm 75x212,5-302,5 29 5/8"x83 3/8"-119 1/8"  
 cm 85x212,5-302,5 33 5/8"x83 3/8"-119 1/8"  
 cm 95x212,5-302,5 37 5/8"x83 3/8"-119 1/8"

**EL2 - EH2**  
 Ingombro stipite  
 Frame external dimensions  
 cm 63x211,5-301,5 24 7/8"x83 3/8"-118 3/4"  
 cm 73x211,5-301,5 28 5/8"x83 3/8"-118 3/4"  
 cm 83x211,5-301,5 32 3/4"x83 3/8"-118 3/4"  
 cm 93x211,5-301,5 37 1/2"x83 3/8"-118 3/4"





## Blues \_

suo elemento distintivo è lo stipite telescopico in alluminio anodizzato: una cornice essenziale, di sofisticato gusto high tech, capace di far risaltare la qualità di ogni finitura: vetro, essenza, laccato opaco e lucido. Il progetto è di Cortesi Design.

The telescopic doorjamb in anodized aluminium forms a distinctive piece: an elemental frame of high-tech sophistication which

emphasizes the quality of each finish of glass, wood, gloss or mat lacquer. The project is by Cortesi Design.







Il design funzionale della cerniera a vista si armonizza con la linea pulita dello stipite per un risultato di grande leggerezza.

The functional, visible hinge complements the clean line of the doorjamb to create an extremely lightweight effect.

**Blues\_194**







Lo stipite telescopico in alluminio anodizzato è adatto a diversi spessori di tavolato.

The telescopic doorjamb in anodized aluminium can be adjusted to the thickness of the door panel.

# Blues

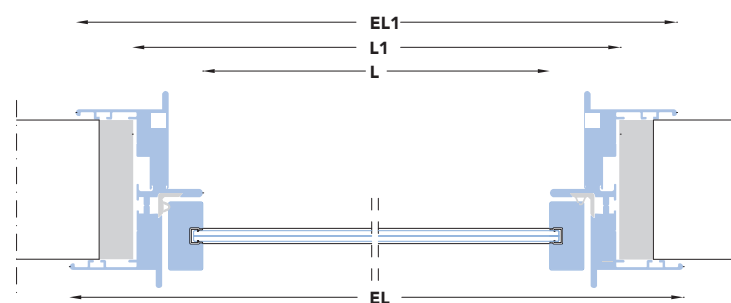

pag. 192 – 194 – 195  
 vetro trasparente  
 / transparent glass  
 pag. 193 – 196 – 197  
 laccato lucido bianco  
 / white gloss lacquer

## blues

Porta a battente, spessore mm 41  
 Battente in vetro di sicurezza  
 trasparente (3 + 3 mm) o opalino,  
 con struttura tamburata, finiture  
 in rovere (sbiancato, moka, grigio)  
 impiallacciato in senso orizzontale;  
 in laccato opaco e lucido nei  
 colori di serie. Telaio perimetrale  
 del vetro e stipite in alluminio  
 anodizzato. Sistema telescopico  
 dello stipite: da 8,5 a 12,5 cm.  
 Guarnizione di battuta.  
 Cerniere esterne a pollice.

Hinged door, 41 mm thick.  
 Door panel in transparent or opal  
 safety glass. (3 + 3 mm), with a  
 hollow core structure in horizontally  
 aligned oak veneer (bleached,  
 moka, grey), trim in matte and  
 glossy finish from our color range.  
 Anodized aluminum exterior frame  
 and jamb. Telescopic doorjamb:  
 from 8.5 to 12.5 cm. Door striker  
 seal. External pivot hinges.

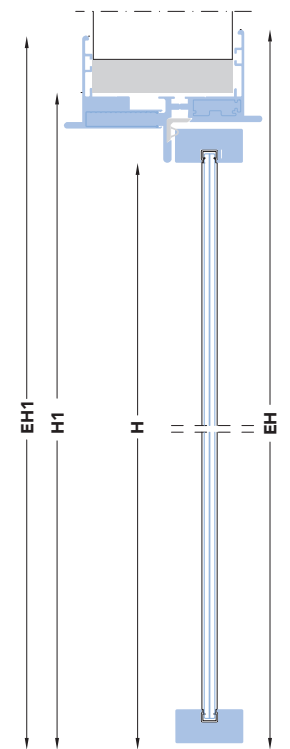

### L

Larghezza luce netta  
 Opening width  
 cm 60 23 5/8"  
 cm 70 27 1/2"  
 cm 80 31 1/2"  
 cm 90 35 3/8"

### L1

Larghezza falso telaio  
 Subframe width  
 cm 68,5 27"  
 cm 78,5 30 7/8"  
 cm 88,5 34 7/8"  
 cm 98,5 38 3/4"

### H

Altezza luce netta  
 Opening height  
 cm 210-300 82 5/8"-118 1/4"

### H1

Altezza falso telaio  
 Subframe height  
 cm 214,5-304,5 84 1/2"-120"

### EL - EH

Ingombro esterno max  
 Max external dim.  
 cm 76x218-308 29 7/8" x 85 7/8"-121 3/8"  
 cm 86x218-308 33 1/8" x 85 7/8"-121 3/8"  
 cm 96x218-308 37 3/4" x 85 7/8"-121 3/8"  
 cm 106x218-308 41 3/4" x 85 7/8"-121 3/8"

### EL1 - EH1

Ingombro esterno  
 External dim.  
 cm 75,3x217,6-307,6 29 5/8" x 85 3/4"-121 1/4"  
 cm 85,3x217,6-307,6 33 5/8" x 85 3/4"-121 1/4"  
 cm 95,3x217,6-307,6 37 1/2" x 85 3/4"-121 1/4"  
 cm 105,3x217,6-307,6 41 1/2" x 85 3/4"-121 1/4"



## Esse + Esse03 \_

si distinguono per la linea originale, che richiama la morbidezza di una forma naturale, il movimento tranquillo e armonico di un'onda. Le superfici curve invitano, da un lato e dall'altro, al gesto dell'aprire e del chiudere e, sottolineate dagli inserti in acciaio inox, creano un sofisticato movimento di riflessi di forte valenza decorativa. Design di Eri Goshen.

These are set apart by the original line which recalls the softness of a natural form and the calm and harmonic movement of a wave. The curved surfaces invite one to open and

to close and, highlighted by the inserts in stainless steel, they create a sophisticated movement of reflections to provide a strong decorative element. Designed by Eri Goshen.

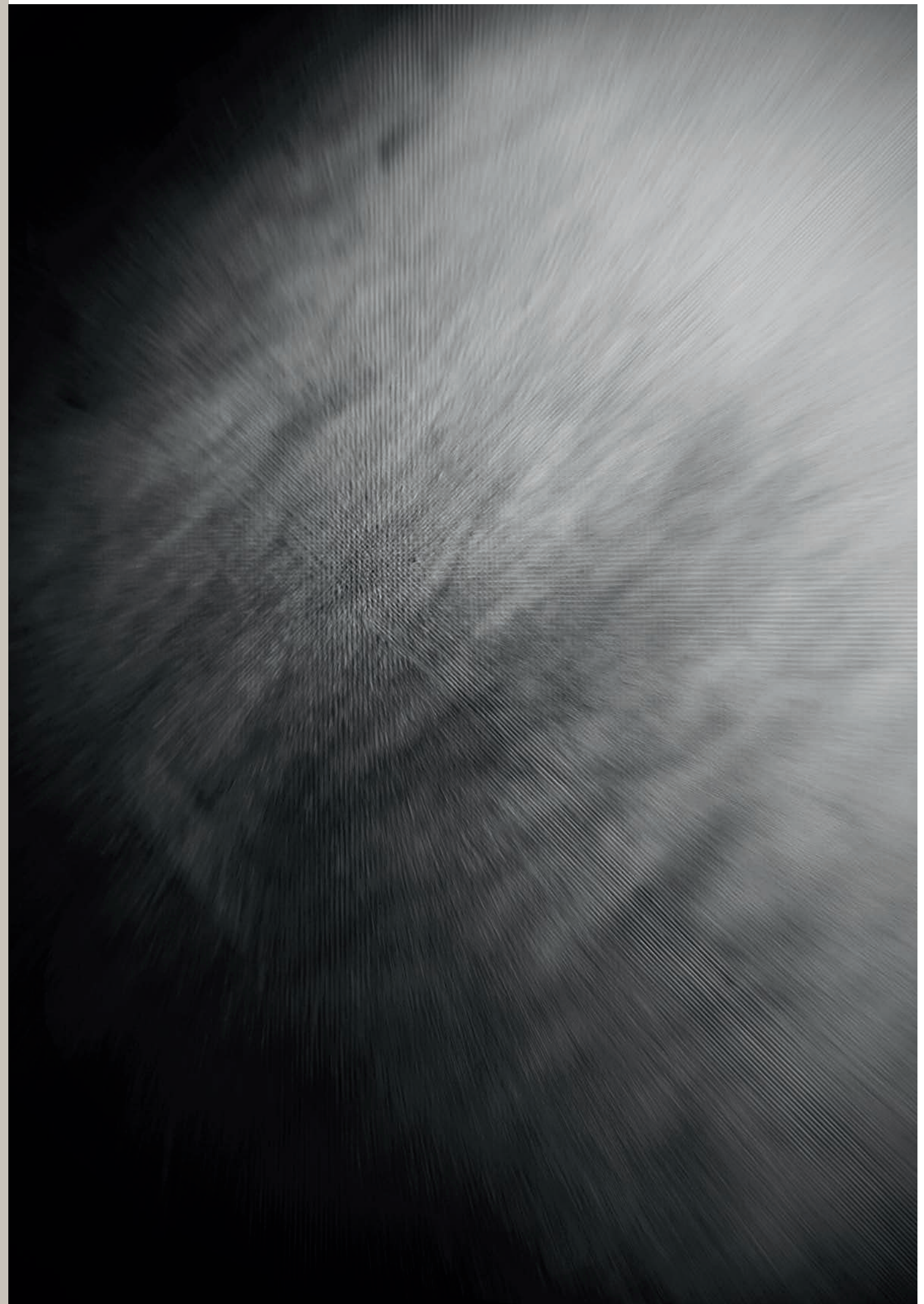







Dettaglio di Esse: lo stipite è in alluminio; la maniglia è Push and Pull, qui in versione curva. La finitura è grigio opaco.

Detail of Esse: the doorjamb is in aluminium, the Push&Pull handle illustrated is the curved version and the finish is matte grey.





Dettaglio di Esse 03 con stipite tradizionale montato su falso telaio in legno.  
Finitura rovere tinto moka.

A detail of the Esse 03 with a traditional doorjamb mounted on a wooden frame.  
Mocha tinted oak finish.

**Esse 03\_206**



# Esse

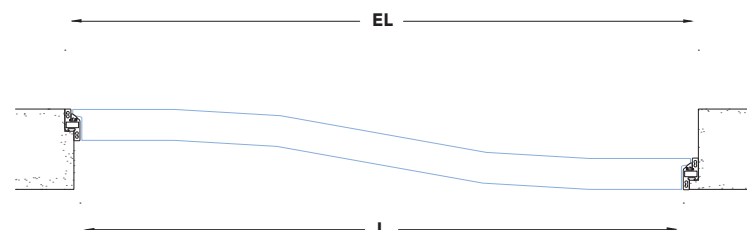

pag. 202 – 203  
204 – 205  
laccato opaco grigio  
/ grey matte lacquer

## Esse

Porta a battente in tamburato, spessore mm 41. Battente con inserti orizzontali in metallo, finiture rovere (sbiancato, moka, grigio) impiallacciato in senso orizzontale; laccato opaco nei colori di serie. Telaio-stipite in alluminio anodizzato. Guarnizione di battuta. Cerniera esterna a pollice.

Hollow core hinged door, 41 mm thick. Door panel with horizontal metal inlays in horizontally veneered oak (bleached, moka, grey) or matte lacquer from standard colour range. Anodized aluminium frame and jamb. Door striker seal. Pivot hinges.

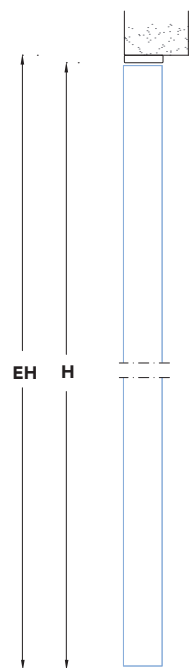

**L**  
Larghezza luce netta  
Opening width  
cm 70 27 1/2"  
cm 80 31 1/2"

**H**  
Altezza luce netta  
Opening height  
cm 210 82 5/8"

**EL-EH**  
Ingombro esterno max  
Max external dim.  
cm 74x210,8 29 1/8"x 83"  
cm 84x210,8 33 1/8"x 83"

# Esse - 03

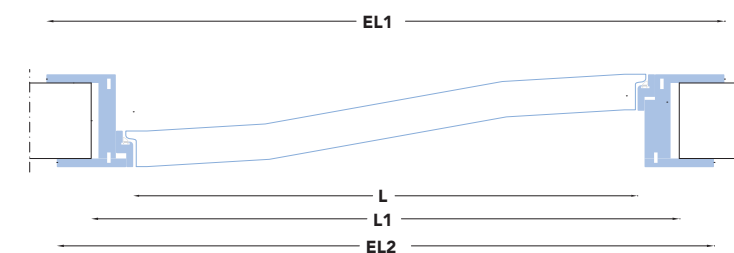

pag. 206 – 207  
rovere moka / mocha oak

## Esse 03

Porta a battente in tamburato, spessore 41 mm. Battente, stipite e coprifili in essenza di rovere (sbiancato, moka, grigio) impiallacciato in senso orizzontale, e in laccato opaco nei colori di serie. Telaio in alluminio anodizzato. Stipite di serie da 9,5 a 12,5 cm. Guarnizione di battuta. Cerniere esterne a pollice. Montaggio su falsi telai tradizionali in legno.

Hollow core hinged door, 41 mm thick. Door panel, jamb and casings in horizontally veneered oak, with stainless steel inlays and in matte lacquer in a series of colours. Anodized aluminium frame. Doorjamb from 9.5 to 12.5 cm. Door striker seal. External pivot hinges. Mounted on traditional wooden subframes.

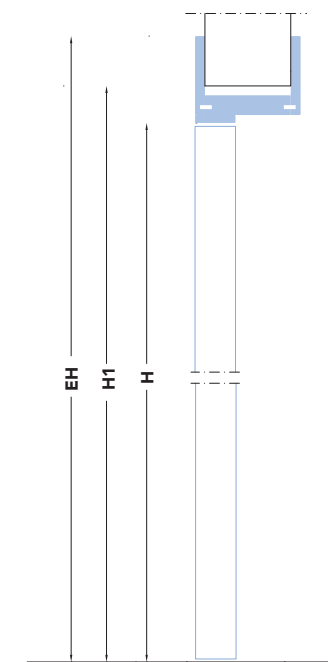

**L**  
Larghezza luce netta  
Opening width  
cm 70 27 1/2"  
cm 80 31 1/2"

**H**  
Altezza luce netta  
Opening height  
cm 210 82 5/8"

**EL1-EH**  
Ingombro esterno max  
Max external dim.  
cm 90x218,8 35 1/2"x 86 1/4"  
cm 100x218,8 39 1/2"x 86 1/4"

**L1**  
Larghezza falso telaio  
Subframe width  
cm 80 30 7/8"  
cm 90 35 3/8"

**H1**  
Altezza falso telaio  
Subframe height  
cm 215 84 1/2"

**EL2-EH**  
Ingombro esterno  
External dim.  
cm 87,6x218,8 35 1/2"x 86 1/4"  
cm 97,6x218,8 39 1/2"x 86 1/4"



## Super —

uno dei modelli storici firmato da Luigi Caccia Dominioni. L'anta, dal bordo arrotondato, è incorniciata dallo stipite in alluminio che ne esalta la superficie ampia e pulita.

One of the classic models designed by Luigi Caccia Dominioni. The door, with its rounded edges, is surrounded by the aluminium frame which exalts the ample and clean surface.

## Tris —

versatile, adattabile, ideale per pareti mobili e attrezzate. Lo stipite la rende adatta a qualsiasi muro dal punto di vista sia estetico sia tecnico.

Versatile, adaptable and ideal for mobile and accessorised walls. The essential form of the doorjamb makes it suitable for any wall, from both an aesthetic and technical standpoint.

## Lcd87 —

montata su telaio tradizionale, è la più classica fra le porte, adatta a tutte le situazioni in cui è necessario lo stipite. L'anta, prevista, in un'ampia gamma di finiture, è disponibile anche in versione scorrevole.

Mounted on a traditional frame, this is the most classic of the doors and is suitable for all those situations which require a frame. The door is also available in the sliding version.







Una associazione di sofisticata bellezza:  
la finitura laccato lucido color prugna  
e lo stipite in alluminio prugna opaco.

An association of sophisticated beauty:  
the plum coloured gloss lacquer finish  
and the plum matte aluminium doorjamb.

**Super** \_\_215







Dettaglio dello stipite con battente chiuso e aperto.

Detail of the doorjamb with the door open and closed.



# Super\_

pag. 212-213-214-215-217  
 laccato lucido prugna  
 /plum gloss lacquer  
 pag. 218-219  
 laccato lucido bianco  
 /white gloss lacquer  
 pag. 220  
 radica laccata lucida  
 /myrtle burl gloss lacquer

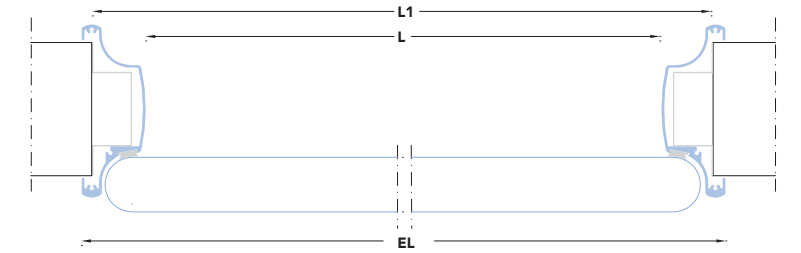

## Super

Porta a battente in tamburato, spessore mm 41. Bordi a sezione arrotondata. Battente laccato lucido al poliestere nei colori di serie; laccato opaco e in essenza di rovere (sbiancato, moka, grigio), e radiche su richiesta. Versione Lux con vetro opalino. Stipite in alluminio laccato opaco. Spessore stipite 10, 11 e 12,5 cm. Feltrino di battuta. Reversibilità del senso di apertura. Cerniere a scomparsa. Montaggio su falsi telai in lamiera verniciata.

Hollow core hinged door, 41 mm thick. Border with rounded edges. Gloss polyester lacquer door panel available in standard range colours, oak veneer (bleached, mocha, grey), briar-root upon request. Lux version features opal glass. Jamb in matte lacquered aluminum. Jamb thickness of 10, 11 and 12.5 cm. Felt protector. Reversible opening direction. Concealed hinges. Mounted on subframe with painted sheet metal.

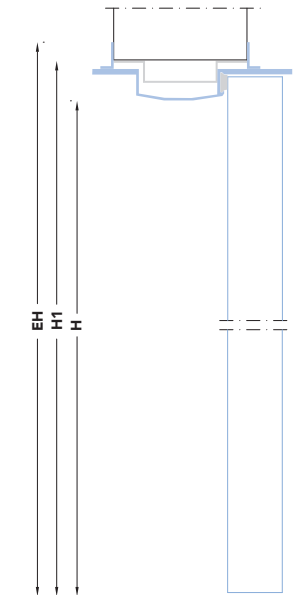

**L**  
 Larghezza luce netta  
 Opening width  
 cm 60 23 3/8"  
 cm 70 27 1/2"  
 cm 80 31 1/2"  
 cm 90 35 1/2"

**L1**  
 Larghezza falso telaio  
 Subframe width  
 cm 68 26 3/4"  
 cm 78 30 3/4"  
 cm 88 34 5/8"  
 cm 98 38 3/4"

**H**  
 Altezza luce netta  
 Opening height  
 cm 210-300 82 5/8"-118 1/4"

**H1**  
 Altezza falso telaio  
 Subframe height  
 cm 213-303 83 7/8"-119 3/8"

**EL-EH**  
 Ingombro esterno max  
 Max external dim.  
 cm 70x214,4-304,4 27 1/2"x 84 1/2"-120"  
 cm 80x214,4-304,4 31 1/2"x 84 1/2"-120"  
 cm 90x214,4-304,4 35 1/2"x 84 1/2"-120"  
 cm 100x214,4-304,4 39 3/8"x 84 1/2"-120"

**T**  
 Spessore muro  
 Wall thickness  
 cm 10 3 7/8"  
 cm 11 4 3/8"  
 cm 12,5 4 7/8"



Associata a materiali caldi e naturali la finitura laccato lucido bianco conferisce all'ambiente un tocco di luce e leggerezza.

Combined with warm and natural materials, the white gloss lacquer finish lends a touch of light and buoyancy to the space.







La superficie nitida e omogenea di Tris appare come ritagliata nel volume del muro.

The neat and harmonious surface of Tris appears to be cut out of the wall itself.

**Tris** \_227



Trasparenza e luminosità connotano  
il modello Lux in laccato lucido con  
inserto in vetro opalino.

This gloss lacquer Lux model with  
opaline glass insert conveys  
transparency and luminosity.

**Tris** \_228



# Tris

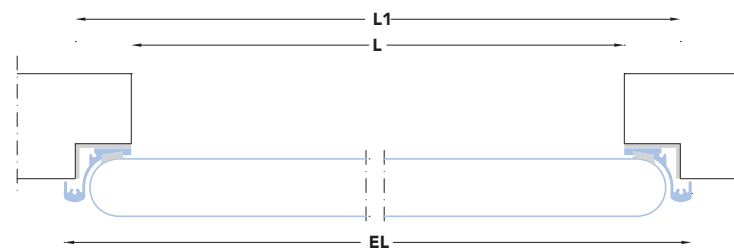

pag. 223 – 224 – 225 – 226  
laccato lucido bianco  
/ white gloss lacquer  
pag. 229  
laccato lucido blu,  
versione Lux con vetro opalino  
/ blue gloss lacquer,  
Lux version with opal glass

## Ttris

Porta a battente in tamburato, spessore mm 41. Bordi a sezione arrotondata. Battente laccato lucido poliestere nei colori di serie, laccato opaco e in essenza di rovere (sbiancato, moka, grigio), e radiche su richiesta. Versione Lux con vetro opalino. Stipite in alluminio laccato opaco. Stipite adatto a tutti gli spessori del muro. Feltrino di battuta. Reversibilità del senso di apertura. Cerniere a scomparsa. Montaggio su falsi telai in ferro trattato con antiruggine.

Hollow core hinged door, 41 mm thick. Border sections with rounded edges. Gloss polyester lacquered door panel available in standard range colours, oak (bleached, moka, grey) and briar-root upon request. Lux version features opal glass. Jamb in matte lacquered aluminium. Jamb adapts to any wall thickness. Felt protector. Reversible opening direction. Concealed hinges. Mounted on antirust metal subframe.

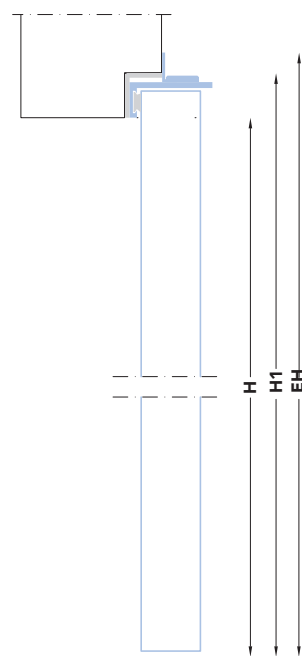

## L

Larghezza luce netta  
Opening width  
cm 60 23 5/8"  
cm 70 27 1/2"  
cm 80 31 1/2"  
cm 90 35 1/2"

## L1

Larghezza falso telaio  
Subframe width  
cm 68 26 3/4"  
cm 78 30 3/4"  
cm 88 34 5/8"  
cm 98 38 3/4"

## H

Altezza luce netta  
Opening height  
cm 210-300 82 5/8"-118 1/4"

## H1

Altezza falso telaio  
Subframe height  
cm 213-303 83 7/8"-119 3/8"

## EL-EH

Ingombro esterno max  
Max external dim.  
cm 70x214,4-304,4 27 1/2"x 84 1/2"-120"  
cm 80x214,4-304,4 31 1/2"x 84 1/2"-120"  
cm 90x214,4-304,4 35 1/2"x 84 1/2"-120"  
cm 100x214,4-304,4 39 3/8"x 84 1/2"-120"

## T

Spessore muro  
Wall thickness  
Tutti gli spessori  
All thicknesses



La bella finitura in laccato lucido cremisi si combina con lo stipite del medesimo colore, ma in versione opaca.

The beautiful finish in crimson red gloss lacquer blends with the frame using the matte version of the same colour.





Dettaglio del bordo arrotondato:  
la linea curva dà una speciale  
morbidezza alla forma dell'anta.

Detail of the rounded edge:  
the curved line lends a particular  
softness to the form of the door.





Nella parte superiore dello stipite,  
le fughe divergenti costituiscono  
una nota di ricercata asimmetria.

The diverging joints in the upper  
part of the doorjamb create a note  
of studied asymmetry.

Lcd87 \_\_238





# Lcd 87

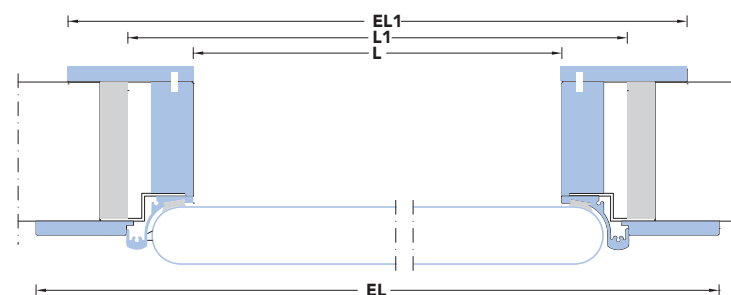

pag. 232 – 234 – 235  
laccato lucido rosso cremisi  
/ crimson red gloss lacquer  
pag. 236 – 237 – 238 – 239  
laccato bianco lucido  
/ white gloss lacquer

## Lcd87

Porta a battente in tamburato, spessore mm 41. Bordi a sezione arrotondata. Battente laccato lucido poliestere nei colori di serie, laccato opaco e in essenza di rovere (sbiancato, moka, grigio), e radiche su richiesta. Versione Lux con vetro opalino. Stipite in medium-density e alluminio laccati opaco. Stipite di serie sino a cm 12. Feltrino di battuta. Reversibilità del senso di apertura. Cerniere a scomparsa. Montaggio su falsi telai tradizionali in legno. Disponibile anche in versione scorrevole esterna o a scomparsa.

Hollow core swing door, 41mm thick. Border sections with rounded edges. Polished enamelled polyester door panel available in the range colours, oak (bleached, moka, grey), and briar-root upon request. Lux version features opal glass. Jamb in MDF and aluminum. Variety of jamb sizes up to 12 cm. Felt protector. Reversible opening direction. Concealed hinges. Mounted on traditional wooden subframe. Pocket or external sliding version also available.

### L

Larghezza luce netta  
Opening width  
cm 60 23 5/8"  
cm 70 27 1/2"  
cm 80 31 1/2"  
cm 90 35 1/2"

### L1

Larghezza falso telaio  
Subframe width  
cm 70 27  
cm 80 30 7/8"  
cm 90 34 7/8"  
cm 100 39 3/8"

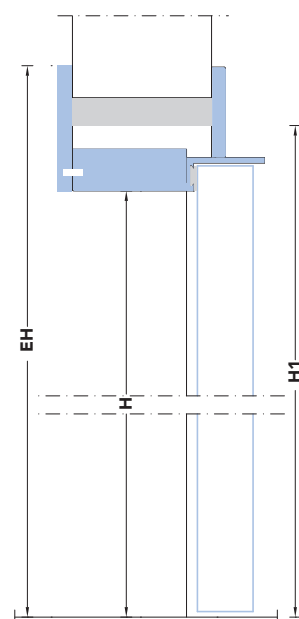

### H

Altezza luce netta  
Opening height  
cm 210-300 82 5/8"-118 1/4"

### H1

Altezza falso telaio  
Subframe height  
cm 215-305 84 1/2"-120 1/8"

### EL1-EH

Dimensione esterna  
External dimensions  
cm 78x219-309 30 3/4"x 86 1/4"-121 3/4"  
cm 88x219-309 34 5/8"x 86 1/4"-121 3/4"  
cm 98x219-309 38 5/8"x 86 1/4"-121 3/4"  
cm 108x219-309 38 5/8"x 86 1/4"-121 3/4"

### EL

Ingombro esterno max  
Max external dimensions  
cm 82,5 32 1/2"  
cm 92,5 36 3/8"  
cm 102,5 40 3/8"  
cm 112,5 44 3/8"



**Maniglie / Door handles**



**A**



**A1**



**A2**



**A3**



**A4**

**A**  
Maniglia Push&Pull  
nichel satinato,  
Push&Pull handle  
satin nichel

**A1 - A2**  
Nottolino Push&Pull  
nichel satinato,  
Privacy lock Push&Pull  
satin nichel

**A3**  
Bocchetta yale,  
Yale escutcheon

**A4**  
Bocchetta patent,  
Patent escutcheon



**B**



**B1**



**B2**



**B3**



**B4**

**B**  
Maniglia Lualdi  
cromo satinato,  
Lualdi handle  
satin chrome

**B1 - B2**  
Nottolino Lualdi  
cromo satinato,  
Privacy lock Lualdi  
satin chrome

**B3**  
Bocchetta yale,  
Yale escutcheon

**B4**  
Bocchetta patent,  
Patent escutcheon

**Maniglie / Door handles**



**C**



**C1**



**C2**



**C3**



**C4**

**C**  
Maniglia Flatiron  
cromo satinato,  
Flatiron handle  
satin chrome

**C1 - C2**  
Nottolino cromo satinato,  
privacy lock satin chrome

**C3**  
Bocchetta yale,  
Yale escutcheon

**C4**  
Bocchetta patent,  
Patent escutcheon



**D**



**D1**



**D2**



**D3**



**D4**

**D**  
Maniglia Outline  
nichel satinato  
Outline handle  
satin nichel,

**D1 - D2**  
Nottolino nichel satinato,  
Privacy lock satin nichel

**D3**  
Bocchetta yale,  
Yale escutcheon

**D4**  
Bocchetta patent,  
Patent escutcheon



**Maniglia Pomm / Pomm handle**



**A**



**B**



**C**



**D**

**A**  
Cromo satinato,  
*Satin chrome*

**B**  
Nero opaco,  
*Mat black*

**C**  
Rovere naturale,  
*Natural oak*

**D**  
Rovere moka,  
*Moka oak*

**Maniglie per Porte scorrevoli / Handles for sliding doors**



**SA**



**SB**



**SC**



**SD**



**S1**



**S2**



**S3**



**S4**

**SA**  
Maniglia ad incasso  
nichel satinato  
*Flush handle  
satin nickel*

**SB - SC**  
Nottolino nichel satinato,  
*Privacy lock satin nickel*

**SD**  
Ditale di trascinamento,  
*Flush finger pull*

**S1**  
Maniglia ad incasso  
cromo satinato  
*Flush handle  
satin chrome*

**S2 - S3**  
Nottolino cromo satinato,  
*Privacy lock satin chrome*

**S4**  
Ditale di trascinamento,  
*Flush finger pull*



Basic - Colori laccato opaco / Matte lacquer finish

101B-O Bianco Gesso Chalk White

201B-O Pergamena Pergamyn

202 B-O Grigio Calce Lime Grey

203 B-O Grigio Tortora Dove Grey

204 B-O Grigio Ferro Iron Grey

205 B-O Cioccolato Chocolate

206 B-O Rubino Ruby

207 B-O Rosso Fuoco Flame Red

Basic - Colori laccato lucido / Gloss lacquer finish

005 B-L Bianco White

308 B-L Bianco Classico Classic White

301 B-L Pergamena Pergamyn

303 B-L Grigio Tortora Dove Grey

309 B-L Grigio Ghiaccio Ice Grey

Basic - Colori laccato lucido / Gloss lacquer finish

025 B-L Grigio Chiaro Light Grey

304 B-L Grigio Ferro Iron Grey

004 B-L Grigio Scuro Dark Grey

007 B-L Verde Green

012 B-L Prugna Plum

006 B-L Amaranzo Rich Purple

024 B-L Rosso Ferrari Ferrari Red



Trend - Colori laccato opaco e lucido / Mat and glossy lacquer finish



501T Bianco Fantasma Phantom White



515T Grigio Talpa Moleskin Grey



541T Argilla Clay



555T Rosso Corsa Racing Red



502T Bianco Titanio Titanium White



516T Nero Ardesia Slate Black



542T Terra dorata Golden Earth



556T Terra di Siena Siena

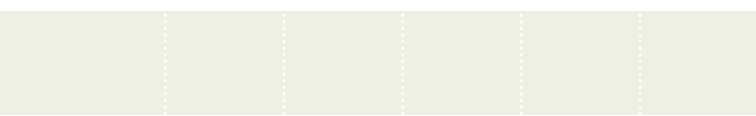

503T Bianco Perlato Pearl White



517T Nero Grafite Graphite Black



543T Nocciola Hazel



557T Terra d'Umbria Raw Umber



504T Bianco Ghiaccio Ice White



518T Nero Notte Night Black



544T Marrone Brown



558T Castano Chestnut



505T Bianco Calcare Limestone White



531T Vaniglia Vanilla



545T Rame Copper



559T Tronco Bark



506T Grigio Nebbia Mist Grey



532T Bianco Latte Milk White



546T Ocra Ochre



560T Rosso Sangria Sangria Red



507T Grigio Scoglio Rock grey



533T Conchiglia Shell



547T Giallo Oro Golden Yellow



561T Rosso Cremisi Crimson Red



508T Grigio Alluminio Aluminium Grey



534T Bianco Antico Antique White



548T Giallo Senape Mustard Yellow



562T Rosa Scuro Dark Pink



509T Grigio Cemento Cement Grey



535T Camoscio Chiaro Light Suede



549T Giallo Limone Lemon Yellow



563T Rosa Pelle Flesh Pink



510T Grigio Nube Cloud Grey



536T Khaki Khaki



550T Arancia Orange



564T Rosso Ciliegia Cherry Red



511T Grigio Fumo Smoke Grey



537T Marrone Pastello Pastel Brown



551T Arancione Fiamma Flaming Orange



565T Rosso Lampone Raspberry Red



512T Grigio Lampione Lamppost Grey



538T Grigio Ombra Umber Grey



552T Sabbia Sand



566T Vinaccia Scuro Dark Pomace



513T Grigio Pomice Pumice Grey



539T Terra Earth



553T Ambra Amber



567T Ribes Nero Blackcurrant



514T Grigio Cenere Ash Grey



540T Seppia Sepia



554T Ruggine Rust



568T Bordeaux Bordeaux

Trend - Colori laccato opaco e lucido / Matte and glossy lacquer finish

Legni / Woods

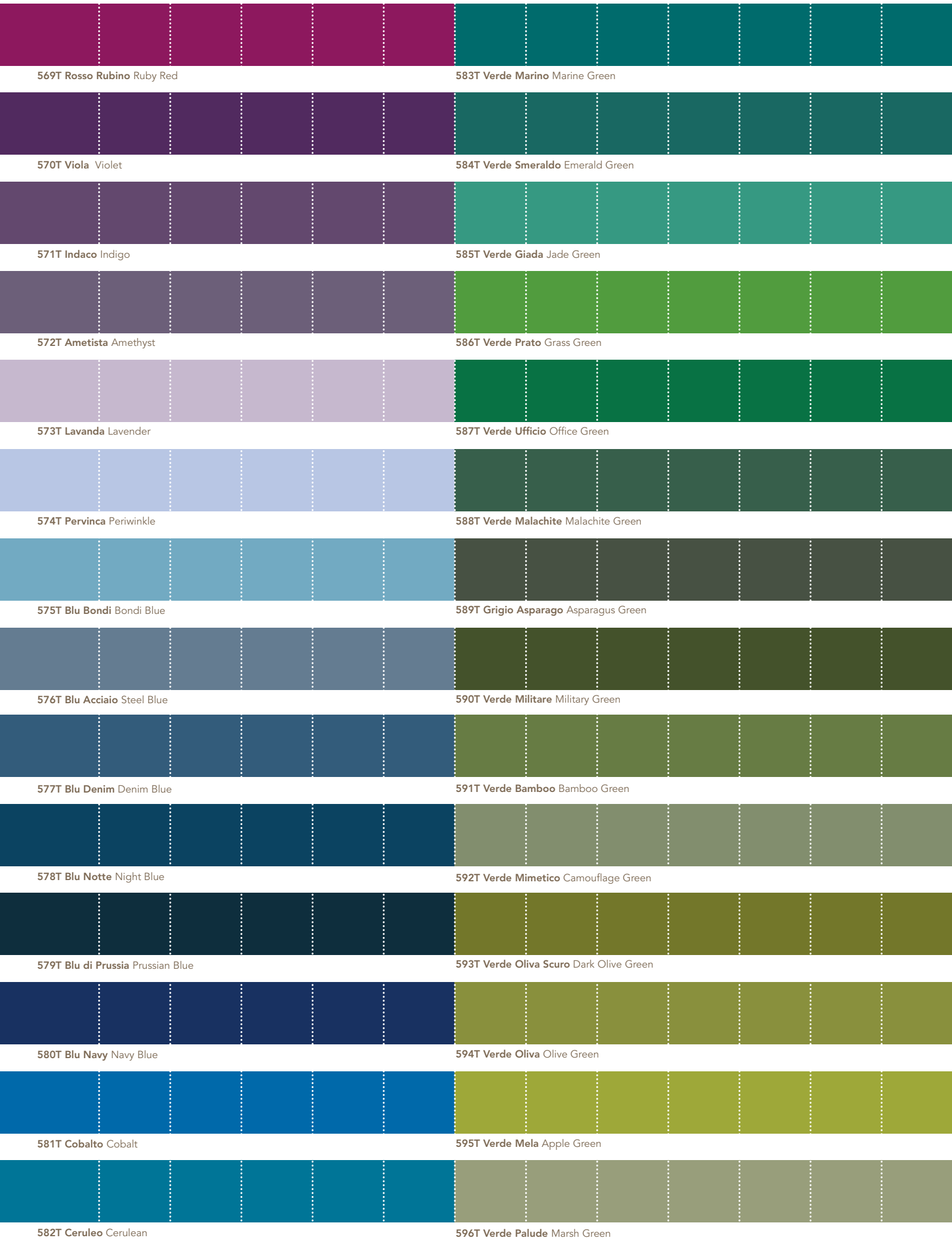

Vetri / Vetri



# opzioni

—

battente lux con vetro / lux - laminated glass door



**L**  
Larghezza luce netta  
Opening width  
cm 60 23 3/8"  
cm 70 27 1/2"  
cm 80 31 1/2"  
cm 90 35 3/8"

**V**  
Larghezza vetro  
Glass width  
cm 30 11 7/8"  
cm 40 15 3/4"  
cm 50 19 3/4"  
cm 60 23 3/8"

**V1**  
Larghezza vetro  
Glass width  
cm 25,3 10  
cm 35,3 13 7/8"  
cm 45,3 17 7/8"  
cm 55,3 21 4/5"

**F - F1**  
Larghezza fascia laterale  
Side strip width  
cm 18 7 1/8"



# opzioni

scorrevole a scomparsa / pocket door

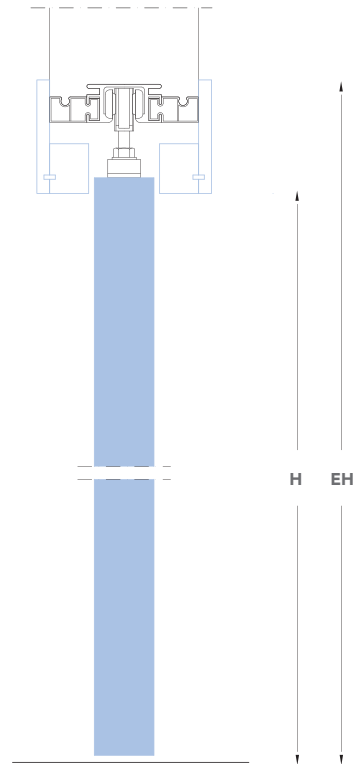
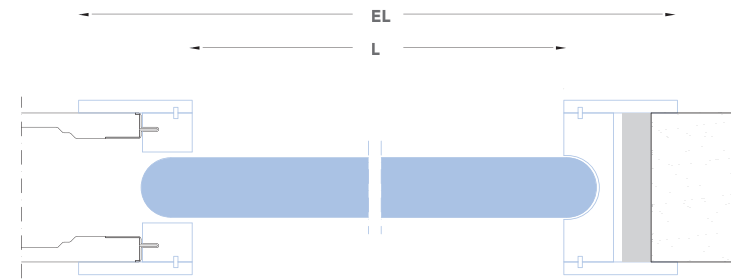

**L**  
Larghezza luce netta  
Opening width  
cm 58 22 7/8"  
cm 68 26 3/4"  
cm 78 30 3/8"  
cm 88 34 7/8"

**H**  
Altezza luce netta  
Opening height  
cm 210-300 82 3/8"-118 1/4"

**EL - EH**  
Ingombro esterno  
Max external dimensions  
cm 76x219-309 29 1/8"x 86 1/4"-121 3/4"  
cm 86x219-309 33 1/8"x 86 1/4"-121 3/4"  
cm 96x219-309 37 3/4"x 86 1/4"-121 3/4"  
cm 106x219-309 41 1/5"x 86 1/4"-121 3/4"

scorrevole a scomparsa / pocket door

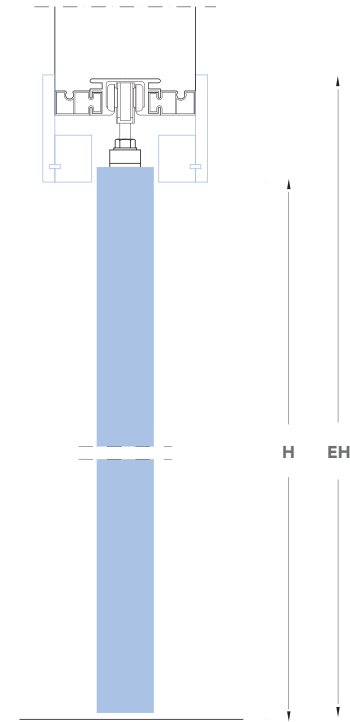
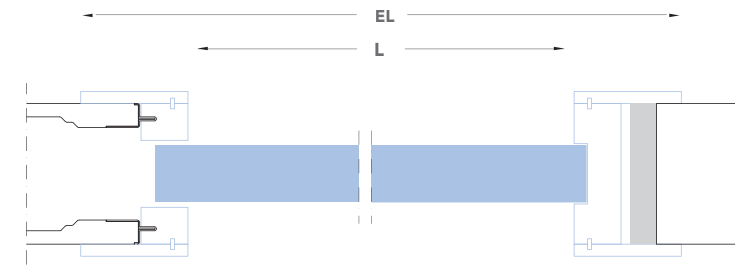

**L**  
Larghezza luce netta  
Opening width  
cm 58 22 7/8"  
cm 68 26 3/4"  
cm 78 30 3/8"  
cm 88 34 7/8"

**H**  
Altezza luce netta  
Opening height  
cm 210-300 82 3/8"-118 1/4"

**EL - EH**  
Ingombro esterno  
Max external dimensions  
cm 74x218-308 29 1/8"x 85 7/8"-121 3/8"  
cm 84x218-308 33 1/8"x 85 7/8"-121 3/8"  
cm 94x218-308 37 3/4"x 85 7/8"-121 3/8"  
cm 104x218-308 41" x 85 7/8"-121 3/8"



Pagina sinistra / Left page:  
Porta scorrevole interno muro con stipite  
Internal sliding door with frame.

Pagina destra / Right page:  
Porta scorrevole interno muro senza stipite  
Internal sliding door without frame.





CONTACT:

ALEXANDRU SCUTURICI

[www.usideinterior.net](http://www.usideinterior.net)

[alexandru@service-usi.eu](mailto:alexandru@service-usi.eu)

0721294477